



1906

Master saddler Wilhelm Reutter starts on the development and production of car bodies, interior fittings and vehicle seats for automobiles, both in custom production and small batches, at his "Stuttgarter Carosserie-u. Radfabrik" body plant.



1920s/1930s

The company produces car bodies and interior fittings for all major car manufacturers. Precursors and prototypes of the Volkswagen (later Beetle) are also manufactured by Reutter on behalf of the Porsche design studio.



1950s

Car bodies, interior fittings and seats for the Porsche 356 go into production at Reutter in Stuttgart. By 1965, the company has built around 60,000 vehicles. Development and subsequent production of reclining seat mechanisms begins.



1965

Launch of the RECARO **sports seat**. The world's first retrofit seat for automobiles is characterized by its revolutionary foam upholstery and distinctive side bolsters.



1967

The "RECARO **shell seat**" is RECARO's first road-legal full shell seat. It raises the bar in safety, lightweight construction and comfort with a body-hugging seat shell, adjustment options and foam upholstery.



1969

The previous RECARO sports seat is renamed the "RECARO **Idealsitz**." At the same time, RECARO introduces a new trademark, which has remained unchanged to this day.



1971

A world first: RECARO unveils the first vehicle seat with an **integrated seat belt** – the RECARO safety seat.



1973

RECARO is the first manufacturer to offer the **anti-submarining** seat upholstery guide, which prevents the occupant from slipping under the belt in the event of an accident. Also making its car seat premiere is RECARO's **extendable seat cushion**, an added comfort feature for tall drivers.



1974

For the world elite in touring car motorsport, RECARO launches its first **racing seat** with a super sturdy double shell made of the fiber-reinforced composite Kevlar – for top-level safety and low weight (6.5 kg).



1977

The new RECARO Airmatic® pneumatic **lumbar support**, **adjustable side bolsters** on the seat cushion and backrest and RECARO's first **electrically adjustable backrest** significantly improve adaptability to individual requirements.



1977

Acoustic comfort: under the name RECAROfonie, the company launches a seat with **stereo loudspeakers** integrated in the headrest.



1984

A seat that remembers. The RECARO CSE comfort seat is the first to have a **memory function**.



1989

Innovation in novel materials: The RECARO A8 sports seat comes with a back shell made of **plastic**.



1990

Cool cabbies: The company introduces the RECARO taxi seat, the first **car seat with ventilation** (RECARO Vent System®).



1995

The world's first racing shell with **head protection**. RECARO's new Pro Racer racing shell revolutionizes safety standards in professional motorsport.



2004

RECARO unveils the **world's first retrofit universal side airbag seat** with ABE for different vehicle models.



2005

RECARO becomes the world's first seat manufacturer to revolutionize seating design with its new **lightweight composite shell**.



2005

RECARO launches the first **full shell with ABE** (German general type approval) on the market.



2013

RECARO Automotive unveils the P 1300 GT, the first **racing shell with fore-aft adjustment**, combining top-level safety with tailored comfort.



2019

The RECARO Podium is the only retrofit shell seat on the market that is approved for use on public roads (**ABE general type approval**) and has **FIA homologation**.



2020

The new versions of our classic seats, the **RECARO Classic Pole Position (ABE)** and the **Classic LX and LS**, turn classic vehicle interiors into pictures of perfection.



2021

From the car to the desk: exclusive Performance and Classic swivel chairs with original car seats: **RECARO Classic LX Star, Cross Sportster CS Star** and **RECARO Speed Star** for the home and workplace.



2023

The first model in RECARO's new generation of sports seats: **the first all-electric 8-way aftermarket sports seat:** RECARO Sport C.



2023

For road and track: The RECARO Podium **in glass fiber reinforced plastic (GFRP)**.
1963 – 2023: We're celebrating 60 years of the RECARO brand.

OVERVIEW OF CAR SEAT RANGE AFTERMARKET SEATS

PREMIUM COMFORT ←

→ SPORTY PERFORMANCE

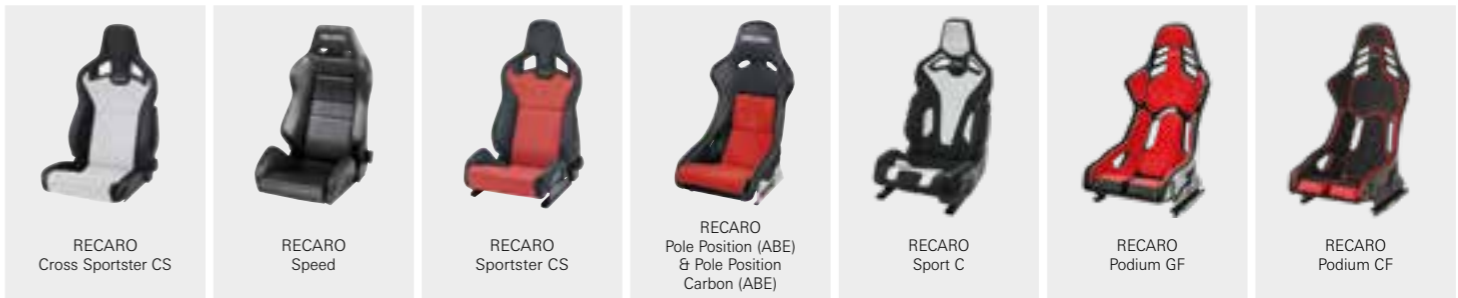

TAILORED COMFORT	Height, length, backrest, tilt adjustment, electric													
	Lumbar support	●	●	●	● Paddable	● Paddable								
	Extendable seat cushion	●	●	●	● M, L	● M, L								
	Adjustable side bolsters, seat cushion	● Electric ES												
	Adjustable side bolsters, backrest	● Electric ES	● Electric	●	● M, L									
	Height adjustment, electric	●		●										
	Tilt adjustment, manual	● E												
	Tilt adjustment, electric	● ES		●										
	Backrest adjustment, manual	● E			●	●								
	Backrest adjustment, electric	● ES	●	●	○	○								
	Adjustable headrest	●	●	●	●	●								
	Pads M (seat for medium build drivers)											● Podium GF M	● Podium CF M	
	Pads L (seat for larger build drivers)											● Podium GF L	● Podium CF L	
	Seat air conditioning	○ E (Climate package) ● ES (Climate package)	● (Climate package)	● (Climate package)								● passive	● passive	
	Seat heating	○ E (Climate package) ● ES (Climate package)	● (Climate package)	● (Climate package)	○	○								
	AGR certified (German Healthier Backs Campaign)	●		●										
Easy Access		●		● M	● M									
Modular seat cushion				●	●									
XL version			●											
Backrest release, manual	●	●	●	●	●									

SAFETY	ABE/component certification	●	●	●	●	●								
	Universal side airbag	○												
	Suitable for 3-, 4-point belt (street use)													
	Competition Seat (FIA 8855-1999)													
	Suitable for 4-, 5-, or 6-point belt (racing use)													
	Suitable for HANS systems													
	FIA approval for 5 years													
	Highly fire-resistant upholstery	●	●	●	●	●								

LIGHTWEIGHT CONSTRUCTION	Seat shell made from carbon and aramid (CFRP/AFRP)													
	Seat shell made of carbon (CFRP)													
	Seat shell glass fiber reinforced plastic (GFRP)													
	Composite materials													
Weight: complete shell (incl. foam and upholstery, without sidemount)														

SPORTY PERFORMANCE	Integrated headrest													
	Suitable for 4-point belts (street use)													
	Special lateral support in the backrest area													
	Special lateral support in the seat cushion area													
	Specially formed shoulder support													
	Dynamic ride performance													
	Slim design													

● Standard features ○ Options/Accessories

OVERVIEW OF CAR SEAT RANGE RACING SEATS		PROFESSIONAL RACING SEATS ←			→ SEMI-PROFESSIONAL RACING SEATS				
		 RECARO P1300 GT LW	 RECARO P 1300 GT	 RECARO Pro Racer SPA & SPA XL	 RECARO Pro Racer SPG & SPG XL	 RECARO Profi SPG & SPG XL	 RECARO Pole Position N.G. (FIA)	 RECARO Podium CF	 RECARO Podium GF
USE*	For GT vehicles/sports cars	●	●	●	●		●	●	●
	For touring vehicles	●	●	●	●		●	●	●
	For rally vehicles			●		●			
COMFORT	Anatomical seat contour	●	●	●	●		●	●	●
	Paddable lumbar support	●	○			●			
	Pad Kit S (Replaceable pads for drivers of small build)	○	○						
	Pad Kit M (Replaceable pads for drivers of medium build)	●	●					● Podium CF M	● Podium GF M
	Pad Kit L (Replaceable pads for drivers of large build)	○	○					● Podium CF L	● Podium GF L
	Seat air conditioning							● passive	● passive
	High seat cushion			○	○				
	Side support pad	○	○						
	Seat in XL version			○	○				
	Flexible sidemount (fore-aft adjustment for preferred sitting positions)	○		○	○				
Fixed sidemount		○	○	○			○	○	
AGR certified (German Healthier Backs Campaign)							●	●	
Friction grip surface in the shoulder and seat area			●	●					
LIGHTWEIGHT	Seat shell made of carbon (CFRP)	●	●				●		
	Seat shell made from carbon and aramid composite (CFRP/AFRP)			●					
	Seat shell glass fiber reinforced plastic (GFRP)				●	●	●		●
	Net seat weight							approx. 4.9 kg	approx. 8.5 kg
	Weight: complete shell (incl. foam and upholstery, without sidemount)	approx. 14.0 kg	approx. 15.3 kg	SPA: approx. 7.0 kg SPA XL: approx. 7.5 kg	SPG: approx. 9.0 kg SPG XL: approx. 10.0 kg	SPG: approx. 7.0 kg SPG XL: approx. 10.0 kg	approx. 7.7 kg	Podium CF M: approx. 7.4 kg Podium CF L: approx. 7.3 kg	Podium GF M: approx. 11.0 kg Podium GF L: approx. 10.9 kg
Aluminum sidemounts			○ SPA XL		○ SPG XL	○			
SAFETY	Advanced Racing Seat (FIA 8862-2009)	●	●						
	Competition Seat (FIA 8855-1999)			●	●	●	●	●	●
	Suitable for 4-, 5- or 6-point belts (racing use)	●	●	●	●	●	●	●	●
	Suitable for HANS systems	●	●	●	●	●	● ¹	● ¹	● ¹
	Shock-absorbent foam	●	●	●	●	●			
	Highly flame-retardant upholstery (ISO 3795)	●	●	●	●	●			
	Highly flame-retardant upholstery (FMVSS 302)			●	●	●	●	●	●
	FIA approval for 10 years	●	●						
	FIA approval for 5 years			●	●	●	●	●	●
ABE/component certification							●	●	
SPORTY PERFORMANCE	Integrated headrest	●	●	●	●	●	●	●	●
	Suitable for 3-, 4-point belt (street use)						●	●	●
	Special lateral support in the backrest area	●	●	●	●	●	●	●	●
	Special lateral support in the seat cushion area	●	●	●	●	●	●	●	●
	Specially formed shoulder support	●	●	●	●	●	●	●	●
	Dynamic ride performance	●	●	●	●	●	●	●	●
	Slim design						●	●	●

● Standard features, ○ Option/accessories * Recommend use for racing series

¹ Temporary removal of pad and pad pins recommended

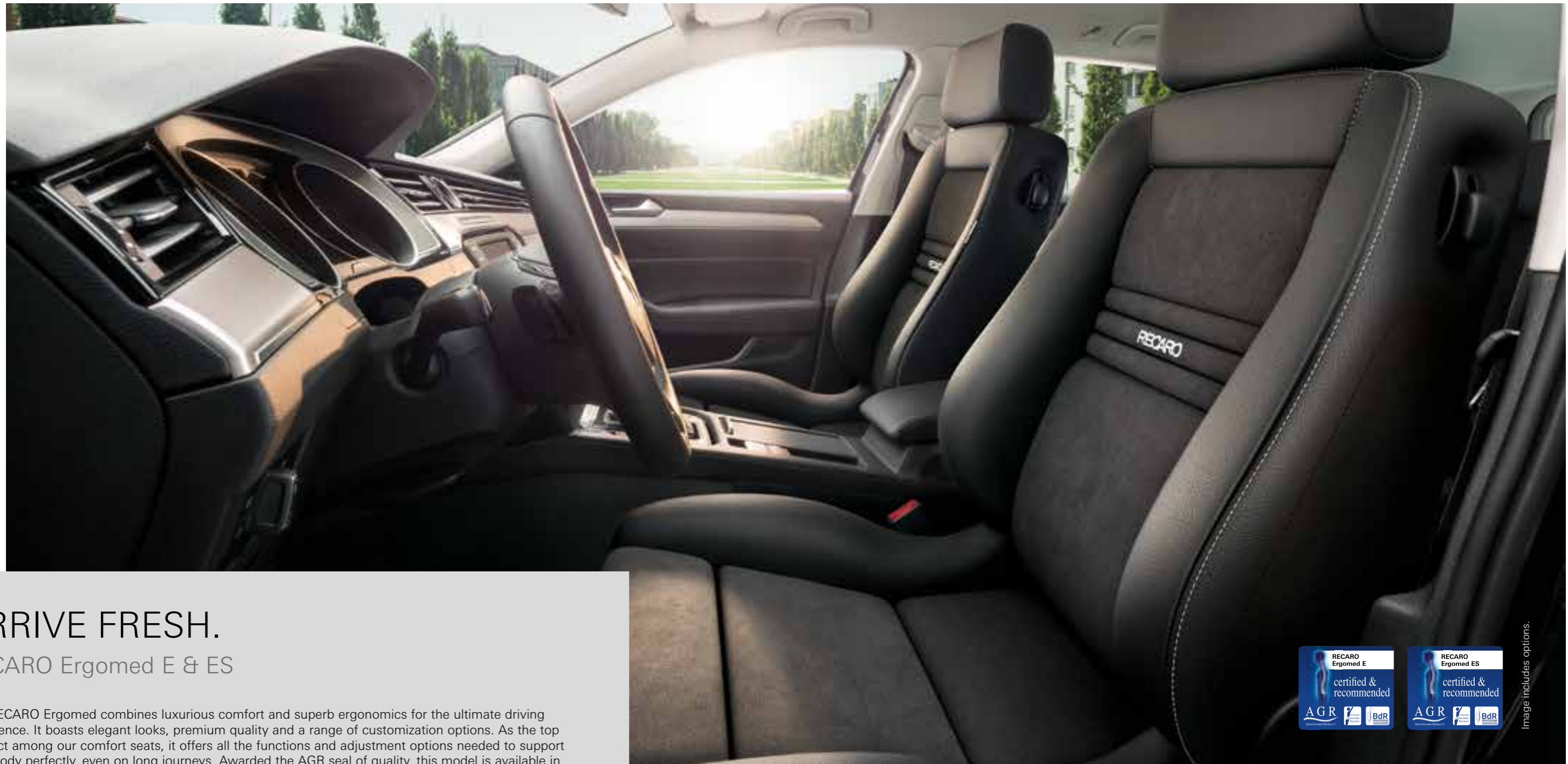

ARRIVE FRESH.

RECARO Ergomed E & ES

The RECARO Ergomed combines luxurious comfort and superb ergonomics for the ultimate driving experience. It boasts elegant looks, premium quality and a range of customization options. As the top product among our comfort seats, it offers all the functions and adjustment options needed to support your body perfectly, even on long journeys. Awarded the AGR seal of quality, this model is available in two configurations, as well as with universal side airbag. Finally, this unique seating experience comes with a climate package comprising seat heating and air conditioning.

Standard features

- + Lumbar support
- + Extendable seat cushion
- + Electric height adjustment
- + Easy-to-operate switch pack
- + Backrest release on both sides
- + Adjustable headrest
- + Seatback pocket

Options

- (at additional cost)**
- + Universal side airbag
 - + RECARO climate package (Ergomed E)

Funding may be available.



Image includes options.

RECARO Ergomed E

- + Standard features
- + Backrest adjustment on both sides
- + Tilt adjustment

RECARO Ergomed ES

- + Standard features
- + Electrically adjustable side bolsters on backrest and seat cushion
- + Electric tilt adjustment
- + Electric backrest adjustment
- + RECARO climate package (heating and air conditioning)

RECARO Ergomed E upholstery options



Nardo black
Artista black Nardo gray
Artista gray

RECARO Ergomed ES with climate package, upholstery options



Nardo black
Artista black Nardo gray
Artista gray Leather black
Artista black Leather black
Dinamica suede black Leather black
perforated

AGR: Approved and recommended by Healthier Backs Association (Aktion Gesunder Rücken e.V.) and the Federal Association of German Back Schools (BdR) e.V. For more information, contact: AGR e.V., Stader Str. 6, 27432 Bremervörde, Germany, Phone +49 4761 926 358 0, www.agr-ev.de/en/back-friendly-products/back-friendly-products/2903-carseats

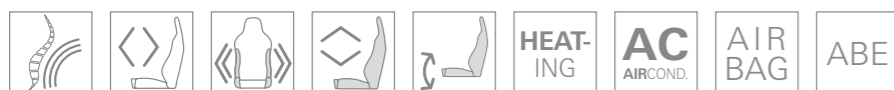

THE SCIENCE OF SITTING.

RECARO Orthopaed

The RECARO Orthopaed is designed with the ultimate focus on the human body. It was developed by our ergonomic design experts for the most discerning drivers who have special requirements when it comes to supporting their spine. Users will love its custom-paddable shoulder support, electrically adjustable backrest side bolsters and multi-chamber lumbar support. Its flat seat cushion makes getting in and out a breeze. These features make the RECARO Orthopaed perfect for high vehicles like SUVs.

Standard features

- + RECARO climate package (heating and air conditioning)
- + Electrically adjustable backrest side bolsters
- + Lumbar support
- + Extendable seat cushion
- + Easy-to-operate switch pack
- + Custom-paddable shoulder support
- + Electric backrest adjustment
- + Adjustable headrest
- + Backrest release on both sides
- + Easy Access to make it easy to get in and out



RECARO climate package



RECARO Orthopaed upholstery options



- Nardo black
Artista black
- Nardo gray
Artista gray
- Leather black
Artista black



- Leather black
Dinamica suede black
- Leather black
perforated



Image includes options.

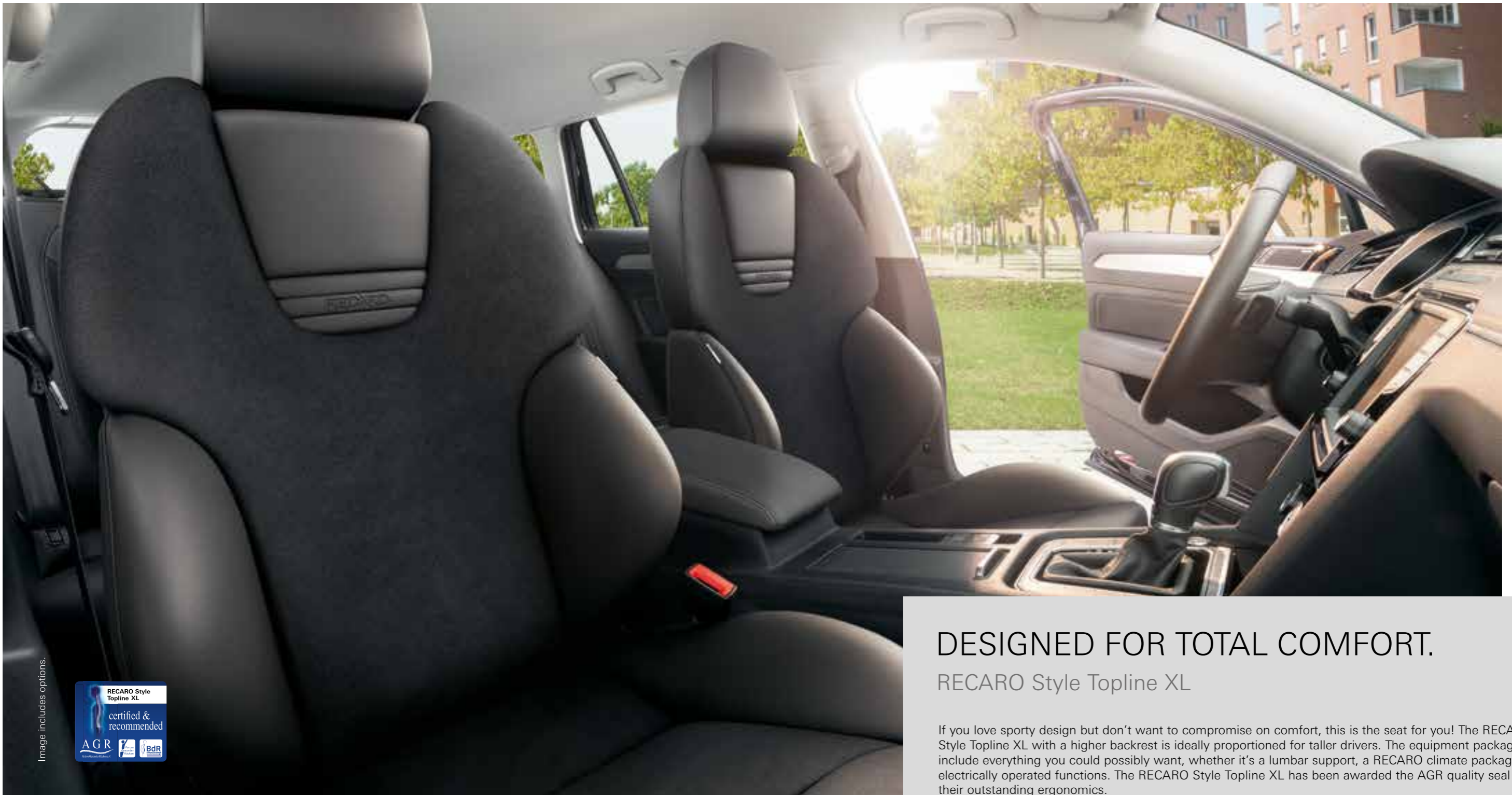

Image includes options.



DESIGNED FOR TOTAL COMFORT.

RECARO Style Topline XL

If you love sporty design but don't want to compromise on comfort, this is the seat for you! The RECARO Style Topline XL with a higher backrest is ideally proportioned for taller drivers. The equipment packages include everything you could possibly want, whether it's a lumbar support, a RECARO climate package or electrically operated functions. The RECARO Style Topline XL has been awarded the AGR quality seal for their outstanding ergonomics.

Standard features

- + Adjustable backrest side bolsters
- + Extendable seat cushion
- + Preformed backrest contour
- + Adjustable headrest
- + Backrest release on both sides
- + Lumbar support
- + Combined electric height and tilt adjustment
- + Easy-to-operate switch pack
- + RECARO climate package (heating and air conditioning)
- + Electric backrest adjustment

RECARO Style Topline XL upholstery options



Nardo black
Artista black

Nardo gray
Artista gray

Leather black
Dinamica suede black

Leather black

AGR: Approved and recommended by Healthier Backs Association (Aktion Gesunder Rücken e.V.) and the Federal Association of German Back Schools (BdR) e. V. For more information, contact: AGR e. V., Stader Str. 6, 27432 Bremervörde, Germany, Phone +49 4761 926 358 0, www.agr-ev.de/en/back-friendly-products/back-friendly-products/2903-carseats





THE FLEXIBLE EXPERT.

RECARO Expert S, M, L

If flexibility is top of your list, look no further! The modular design of the RECARO Expert adapts to different body sizes. It's available with S, M and L seat cushions that vary in the length of the seat surface and the height and contours of the side bolsters. Shorter drivers will find that the short seat cushion and flat side bolsters make getting in and out a breeze (S version), while taller drivers will appreciate the extra upper leg support provided by the long seat cushion and the high, prominent side bolsters (L version). Adjustable backrest side bolsters come as standard, rounding off the perfect body support. Feel your driving performance soar!



RECARO Expert S



RECARO Expert L

Standard features

- + Paddable lumbar support
- + Preformed side bolsters
- + Backrest adjustment on both sides
- + Adjustable headrest
- + Backrest side bolsters adjustable on both sides
- + Backrest release on both sides

Options (at additional cost)

- + Seat heating

RECARO Expert S

- + Seat cushion for people of small to medium build: short seat cushion with flat side bolsters

RECARO Expert M

- + Easy Access to make it easy to get in and out
- + Seat cushion for people of medium to large build: long seat cushion with less pronounced, very flat side bolsters
- + Extendable seat cushion

RECARO Expert L

- + Seat cushion for people of medium to large build: long seat cushion with pronounced side bolsters
- + Extendable seat cushion

RECARO Expert S, M, L upholstery options



Nardo black Artista black Nardo gray Artista gray Ambla leather black Artista black Ambla leather black Dinamica suede black Ambla leather black

Image includes RECARO Expert M options.



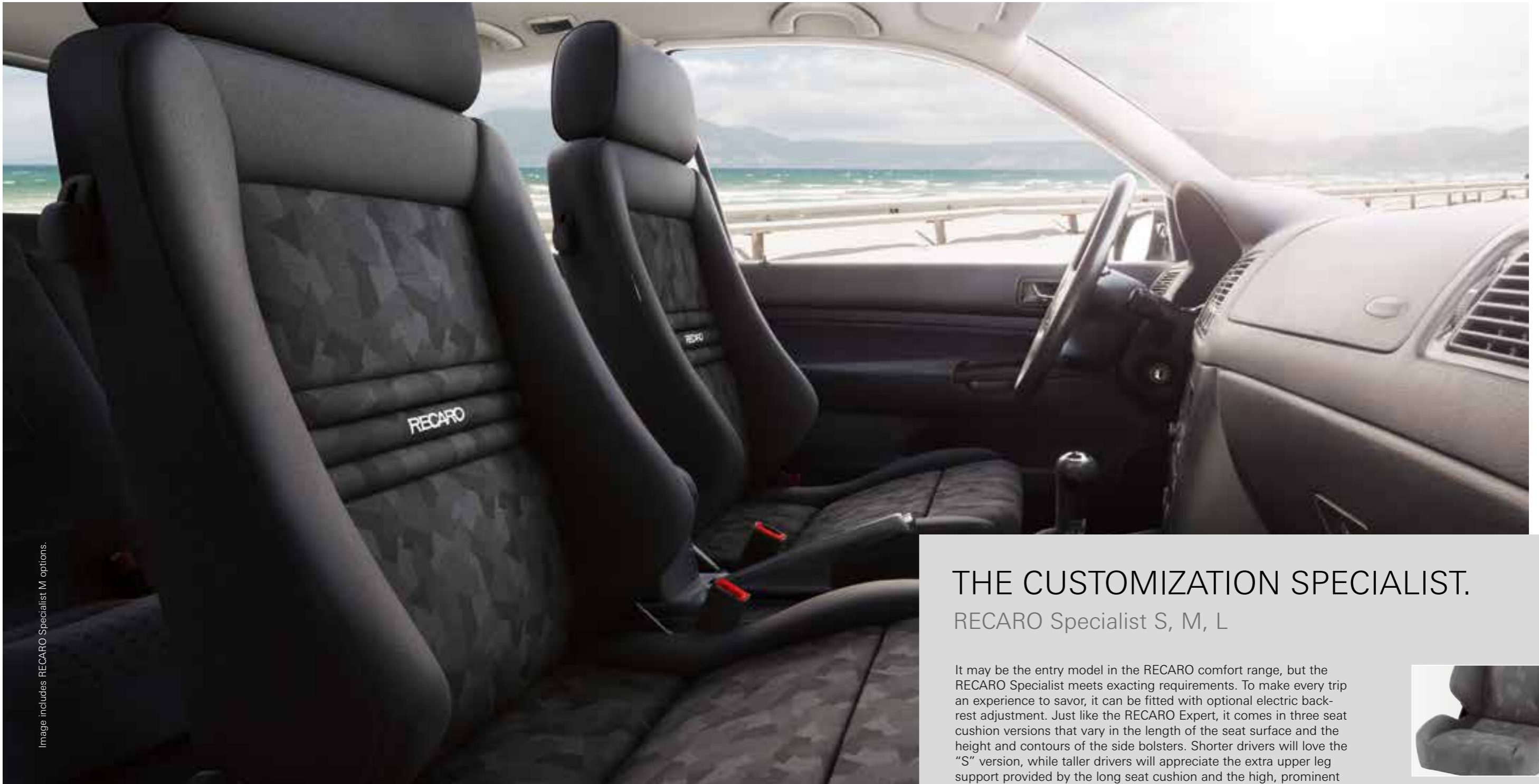

Image includes RECARO Specialist M options.

THE CUSTOMIZATION SPECIALIST.

RECARO Specialist S, M, L

It may be the entry model in the RECARO comfort range, but the RECARO Specialist meets exacting requirements. To make every trip an experience to savor, it can be fitted with optional electric backrest adjustment. Just like the RECARO Expert, it comes in three seat cushion versions that vary in the length of the seat surface and the height and contours of the side bolsters. Shorter drivers will love the "S" version, while taller drivers will appreciate the extra upper leg support provided by the long seat cushion and the high, prominent side bolsters in the "L" version.



RECARO Specialist S



RECARO Specialist L

RECARO Specialist S

- + Seat cushion for people of small to medium build: short seat cushion with flat side bolsters

RECARO Specialist M

- + Easy Access to make it easier to get in and out
- + Seat cushion for people of medium to large build: long seat cushion with less pronounced, very flat side bolsters
- + Extendable seat cushion

RECARO Specialist L

- + Seat cushion for people of medium to large build: long seat cushion with pronounced side bolsters
- + Extendable seat cushion

Standard features

- + Paddable lumbar support
- + Preformed side bolsters
- + Backrest adjustment on both sides
- + Adjustable headrest
- + Backrest release on both sides

Options

- (at additional cost)**
- + Seat heating

RECARO Specialist S, M, L upholstery options



Nardo black
Artista black
Nardo gray
Artista gray
Ambla leather black
Artista black
Ambla leather black
Dinamica suede black
Ambla leather black



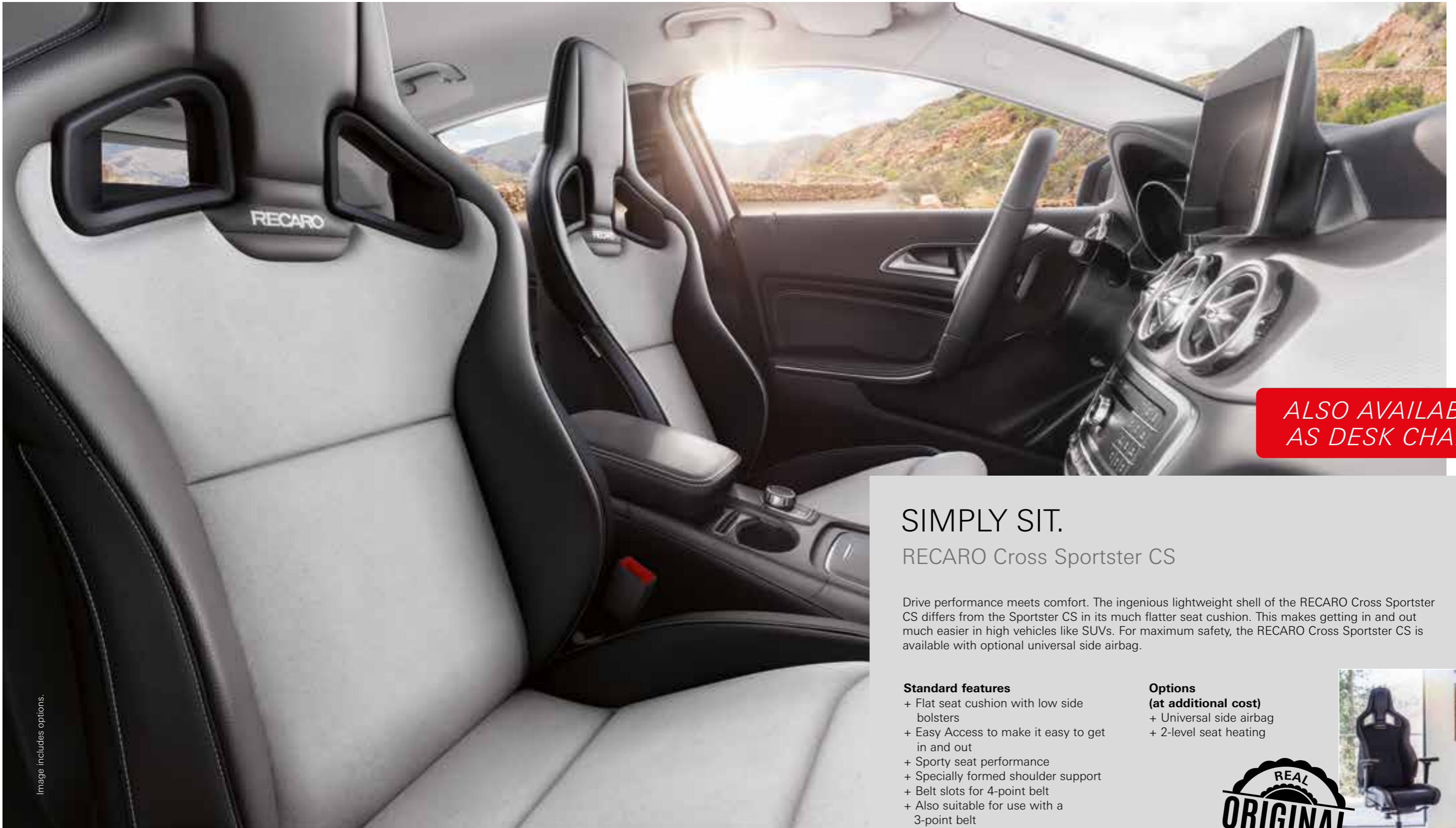

ALSO AVAILABLE AS DESK CHAIR!

SIMPLY SIT.

RECARO Cross Sportster CS

Drive performance meets comfort. The ingenious lightweight shell of the RECARO Cross Sportster CS differs from the Sportster CS in its much flatter seat cushion. This makes getting in and out much easier in high vehicles like SUVs. For maximum safety, the RECARO Cross Sportster CS is available with optional universal side airbag.

Standard features

- + Flat seat cushion with low side bolsters
- + Easy Access to make it easy to get in and out
- + Sporty seat performance
- + Specially formed shoulder support
- + Belt slots for 4-point belt
- + Also suitable for use with a 3-point belt
- + Backrest adjustment
- + Integrated headrest
- + Backrest release
- + Integrated sidemount

Options

- (at additional cost)**
- + Universal side airbag
 - + 2-level seat heating



RECARO Cross Sportster CS Star

RECARO Cross Sportster CS upholstery options



Nardo black
Artista black
Ambla leather black
Ambla leather black
Dinamica suede black

RECARO Cross Sportster CS with heating, upholstery options



Ambla leather black
Dinamica suede black
Ambla leather black
Dinamica suede red
Ambla leather black
Dinamica suede silver
Leather black



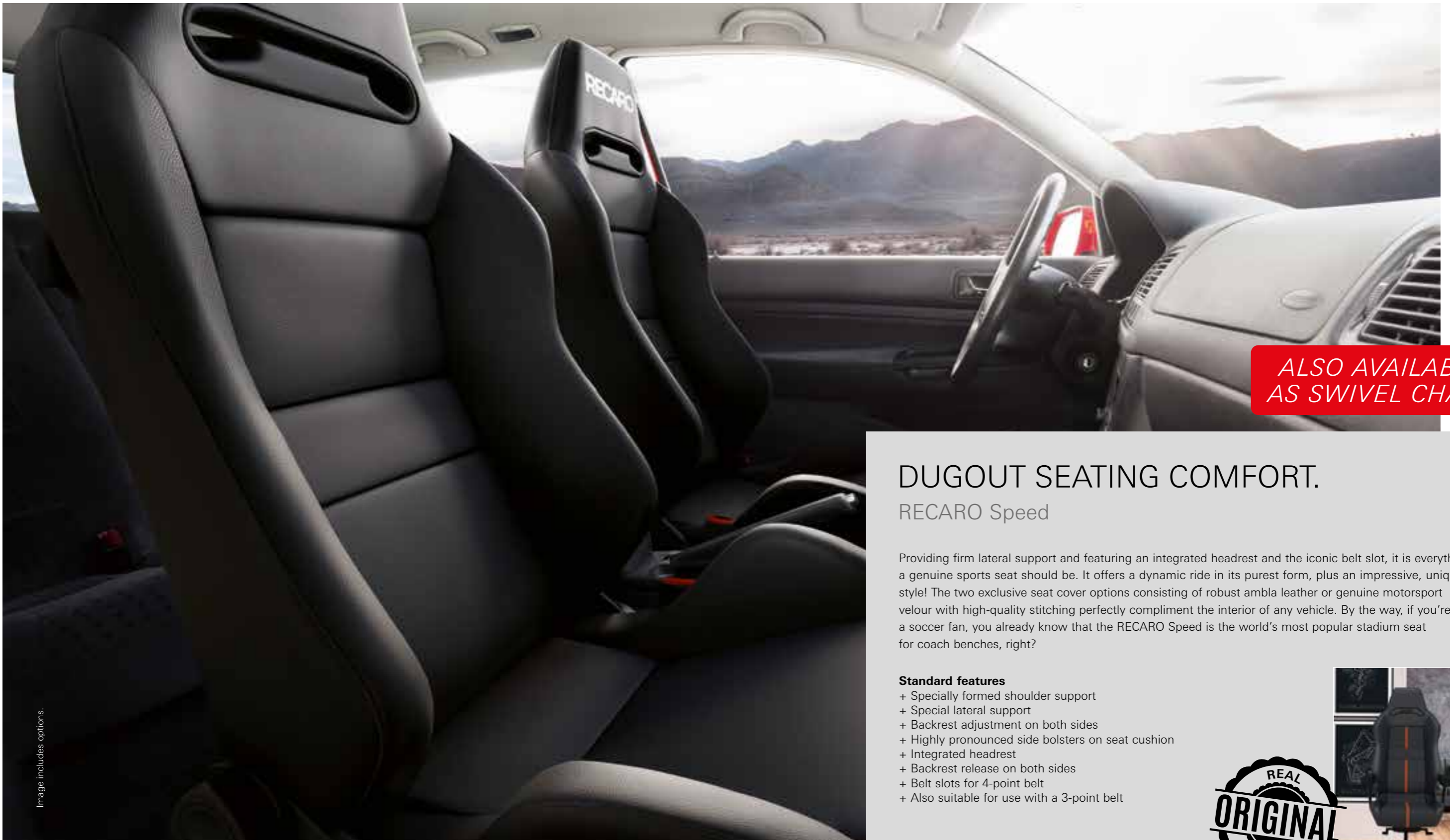

ALSO AVAILABLE AS SWIVEL CHAIR!

DUGOUT SEATING COMFORT.

RECARO Speed

Providing firm lateral support and featuring an integrated headrest and the iconic belt slot, it is everything a genuine sports seat should be. It offers a dynamic ride in its purest form, plus an impressive, unique style! The two exclusive seat cover options consisting of robust ambla leather or genuine motorsport velour with high-quality stitching perfectly compliment the interior of any vehicle. By the way, if you're a soccer fan, you already know that the RECARO Speed is the world's most popular stadium seat for coach benches, right?

Standard features

- + Specially formed shoulder support
- + Special lateral support
- + Backrest adjustment on both sides
- + Highly pronounced side bolsters on seat cushion
- + Integrated headrest
- + Backrest release on both sides
- + Belt slots for 4-point belt
- + Also suitable for use with a 3-point belt



RECARO Speed Star

Image includes options.

RECARO Speed upholstery options



Velour black with silver stitching Ambla leather black

ROAD 3-4-POINT BELT ABE

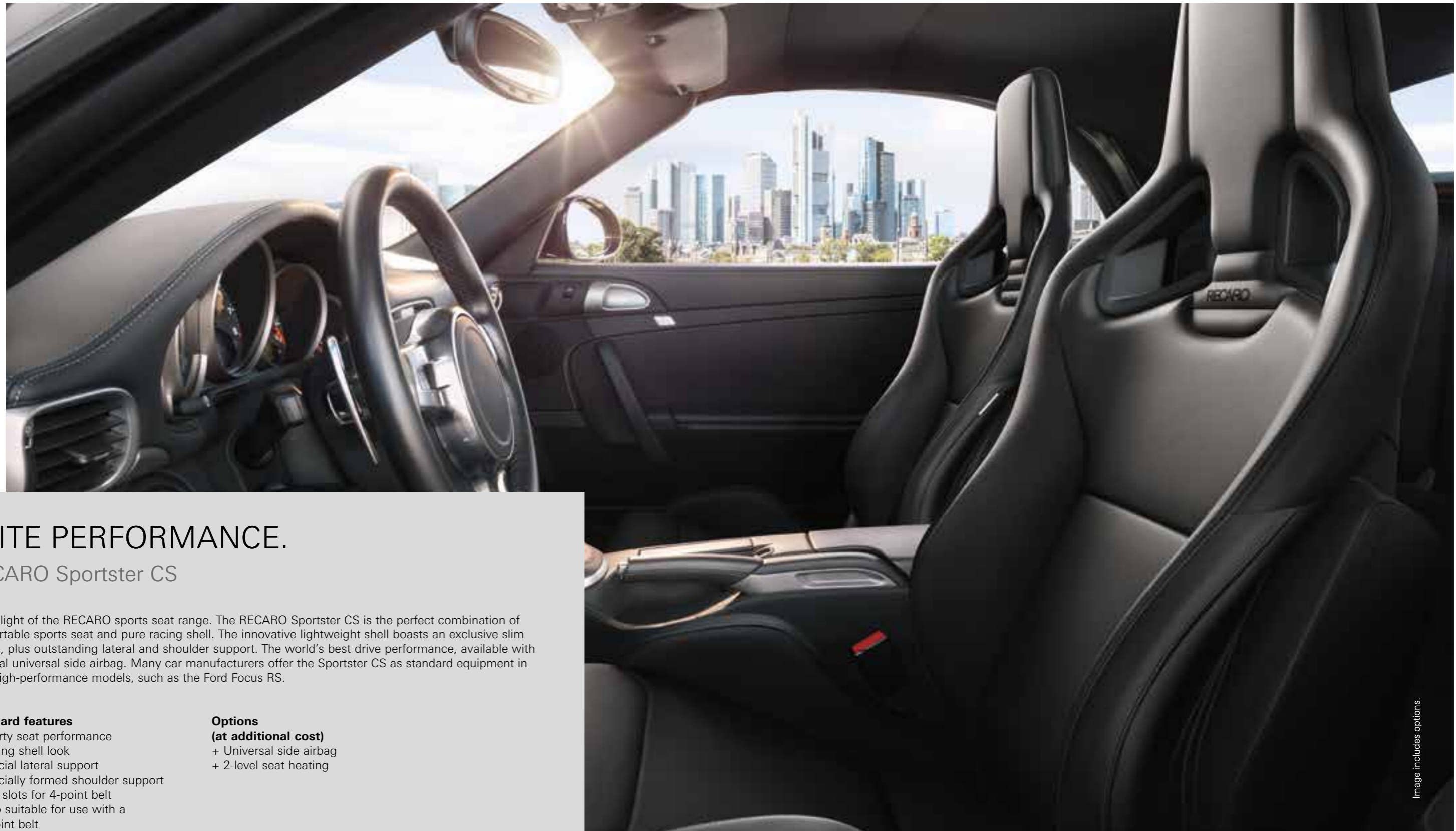

ELITE PERFORMANCE.

RECARO Sportster CS

A highlight of the RECARO sports seat range. The RECARO Sportster CS is the perfect combination of comfortable sports seat and pure racing shell. The innovative lightweight shell boasts an exclusive slim design, plus outstanding lateral and shoulder support. The world's best drive performance, available with optional universal side airbag. Many car manufacturers offer the Sportster CS as standard equipment in their high-performance models, such as the Ford Focus RS.

Standard features

- + Sporty seat performance
- + Racing shell look
- + Special lateral support
- + Specially formed shoulder support
- + Belt slots for 4-point belt
- + Also suitable for use with a 3-point belt
- + Backrest adjustment
- + Integrated headrest
- + Backrest release
- + Integrated sidemount

Options

- (at additional cost)**
- + Universal side airbag
 - + 2-level seat heating

Image includes options.

RECARO Sportster CS upholstery options



RECARO Sportster CS with heating, upholstery options



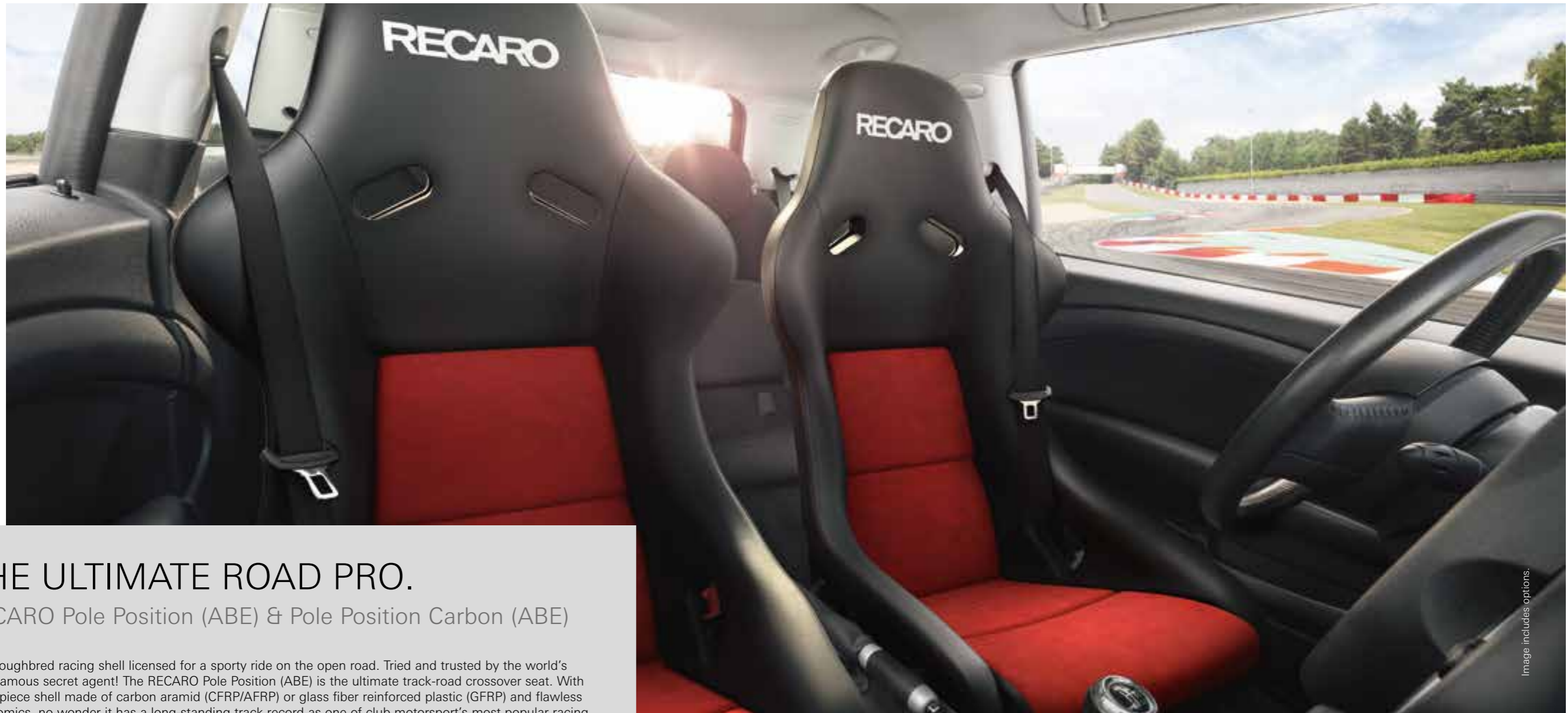

Image includes options.

THE ULTIMATE ROAD PRO.

RECARO Pole Position (ABE) & Pole Position Carbon (ABE)

A thoroughbred racing shell licensed for a sporty ride on the open road. Tried and trusted by the world's most famous secret agent! The RECARO Pole Position (ABE) is the ultimate track-road crossover seat. With a one-piece shell made of carbon aramid (CFRP/AFRP) or glass fiber reinforced plastic (GFRP) and flawless ergonomics, no wonder it has a long-standing track record as one of club motorsport's most popular racing shells. Many exclusive car manufacturers upgrade their top performance models with the Pole Position.

Standard features

- + Belt slots for 4-point belt
- + Also suitable for use with a 3-point belt
- + Integrated headrest
- + ABE (German general type approval) component certification**
- + Paddable lumbar support

Accessories

(at additional cost)

- + Aluminum sidemount
- + Steel sidemount

**** Seat with ABE (German general type approval)/component certification with 3-point belt available for many vehicles.**

For further information on specific vehicles, please contact an authorized RECARO partner (ABE/component certification only in conjunction with RECARO baseframe and sidemount).

RECARO Pole Position (ABE)

- + Standard features
- + Glass fiber reinforced plastic (GFRP) seat shell
- + Weight approx. 7.0 kg (without sidemount and baseframe)

RECARO Pole Position Carbon (ABE)

- + Standard features
- + Carbon aramid (CFRP/AFRP) seat shell
- + Weight approx. 4.5 kg (without sidemount and baseframe)

RECARO Pole Position (ABE) upholstery options



Velour black Nardo black Ambla leather black Ambla leather black Ambla leather black Leather black
Artista black Dinamica suede red Dinamica suede black

RECARO Pole Position Carbon (ABE) upholstery options



Velour black Leather black

Accessories



Aluminium sidemount Steel sidemount





Image includes options.

FROM SUMMER 2023,
ALSO AVAILABLE WITH
SIDE AIRBAG

WORLD FIRST

THE FIRST ALL-ELECTRIC 8-WAY AFTERMARKET SPORTS SEAT.

RECARO Sport C

The new RECARO Sport C embodies everything about the RECARO brand: performance, quality, innovation, safety and comfort. And our passion for sporty cars and outstanding craftsmanship. The result is a unique sports seat designed for a very special driving experience. Its pioneering design, combined with all-electric adjustments and superior body support, will wow car enthusiasts while also delivering premium performance the like of which the aftermarket has never seen. The one and only new RECARO Sport C.



Image includes options.

RECARO Sport C

The first model in RECARO's new generation of sports seats: Where man meets machine, it gives you instant feedback. With a low center of gravity, firm, compact upholstery, and the necessary freedom of movement for the arms, the RECARO Sport C helps you keep control on corners and truly enjoy the experience of driving. And with RECARO's hallmark ultra-slim backrest contour – designed with both aesthetics and comfort in mind – passengers in the back seat will relish all the extra legroom. With a whole range of electric adjustment options, premium car owners can totally indulge in their new seats.

Standard features

- + All-electric 8-way adjustment*: backrest, fore-and-aft adjustment, seat height, seat angle
- + Easy-to-operate switch pack
- + Ultra-slim design
- + Very low hip point**
- + Fully upholstered headrest as standard
- + Sporty side bolsters in backrest and on seat bottom
- + Belt slots for 4-point belt
- + Also suitable for use with a 3-point belt
- + Specially formed shoulder support

- + Extendable seat cushion
- + Lumbar support (4-way)
- + Lightweight: only approx. 24 kg per seat
- + Innovative structure for maximum safety

Options (at additional cost)

- + 2-level seat heating
- + Backrest release (for 2/3 door cars)
- + Additional seat cover options
- + Side airbag (available from summer 2023)



RECARO Sport C upholstery options



Leather white
Dinamica suede black Leather black
Dinamica suede black Dinamica suede grey/
decorative rally strips Leather black



* All-electric 8-way adjustment:

- Backrest: adjustable 15° forwards, 45° backwards
- Fore-and-aft adjustment: 240 mm
- Height adjustment: 60 mm
- Tilt adjustment: 6°

** Hip point: 155 mm

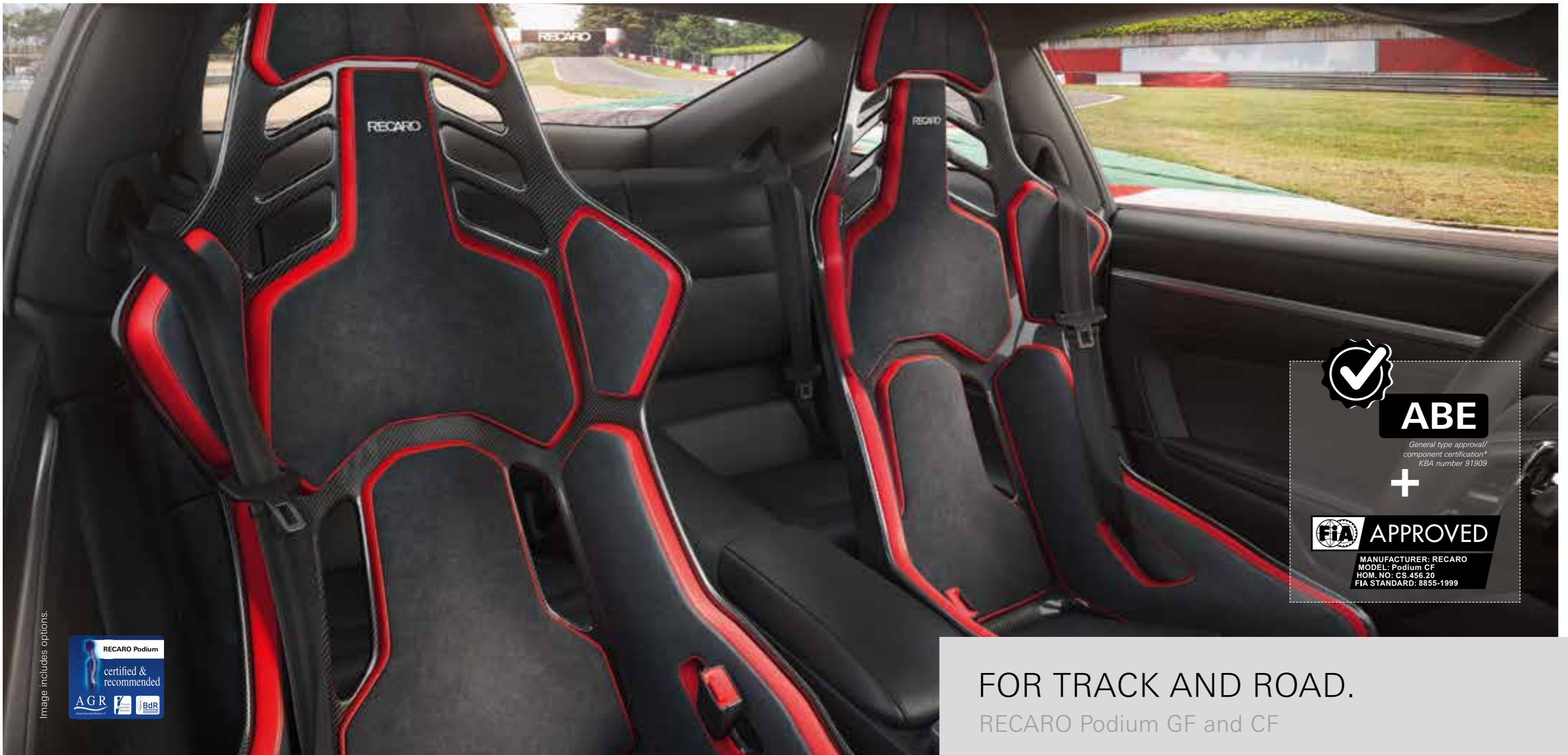



ABE
General type approval/
component certification*
KBA number 91909

+



APPROVED

MANUFACTURER: RECARO
MODEL: Podium CF
HOM. NO: CS.456.20
FIA STANDARD: 8855-1999

Image includes options:



FOR TRACK AND ROAD.

RECARO Podium GF and CF

The new RECARO Podium is much more than a thoroughbred GFRP or CFRP shell seat. It's a pioneering seat design for the contrasting demands of road and track. It's not just its sleek outline, visible structures or motorsport-inspired pads in varying thicknesses that make heads turn. The Podium stands out because of its superior quality and exceptional performance on all road types – for driving day-to-day and at the limit. The RECARO Podium is the only retrofit shell seat on the market that is approved for use on public roads and has FIA homologation. Racing technology doesn't get better than this!

To meet our consistently high standards of innovation, quality, comfort and, most importantly, safety, the RECARO Podium went through intensive testing on the toughest racetracks in the world during development.

The suave combination of original Alcantara® fabrics and exclusive leather together with the passive ventilation of the open back shell and airy pad contours make even the longest of routes the most perfect of pleasures. In addition, the RECARO Podium is the first racing shell ever to be awarded the coveted seal of quality from AGR e.V, the German Campaign for Healthier Backs – a reliable decision-making aid when buying back-friendly products. The shell is also super light – but, of course, that goes without saying.

RECARO Podium GF/CF M for medium build drivers

The RECARO Podium M is suitable for medium build drivers. The approx. **20 mm** thick pads are available in all of the listed cover options.



approx. 20 mm

RECARO Podium GF/CF L for larger build drivers

The RECARO Podium L is suitable for larger build drivers. The approx. **10 mm** thick pads are available in all of the listed cover options.



approx. 10 mm

AGR: Approved and recommended by Healthier Backs Association (Aktion Gesunder Rücken e.V.) and the Federal Association of German Back Schools (BdR) e. V. For more information, contact: AGR e. V., Stader Str. 6, 27432 Bremervörde, Germany, Phone +49 4761 926 358 0, www.agr-ev.de/en/back-friendly-products/back-friendly-products/4853-car-racing-shells



NEW

FROM SUMMER 2023,
ALSO AVAILABLE WITH
SIDE AIRBAG

RECARO Podium GF (Glass fiber reinforced plastic GFRP)

Standard features

- + Glass fiber reinforced plastic (GFRP) seat shell
- + RECARO Podium GF **M**: with pads for medium build drivers
- + RECARO Podium GF **L**: with pads for larger build drivers
- + ABE and FIA homologation
- + Suitable for track and road
- + Sporty seat performance
- + Sleek racing seat look
- + Special lateral support
- + Specially formed shoulder support
- + Integrated headrest
- + High-grade surface in mirror-finish black gelcoat
- + Road use: with 3- or 4-point belt
- + FIA: with 4-, 5- or 6-point belt

- + Developed for the use of HANS systems¹
- + **One of the lightest seats in the world²:**
RECARO Podium GF L: approx. 10.9 kg
RECARO Podium GF M: approx. 11.0 kg (including pads in black velour)
- + Net seat weight: only approx. 8.5 kg

Options (at additional cost)

- + Seat cover options with Alcantara®/leather
- + Side airbag³ (available from summer 2023)

Accessories (at additional cost)

- + ABE sidemount
- + FIA sidemount
- + Universal sidemount
- + Pad Kit M and L in the three cover options

* **Seat with ABE (German general type approval)/component certification with 3-point belt available for many vehicles.** For further information on specific vehicles, please contact an authorized RECARO partner (ABE/component certification only in conjunction with RECARO baseframe and sidemount).

** **FIA homologation 8855-1999** only in conjunction with the specified sidemount.



MANUFACTURER: RECARO
MODEL: Podium GF
HOM. NO: CS.XXX.XX
FIA STANDARD: 8855-1999

Homologation number
not yet defined at time of printing.



ALCANTARA

RECARO Podium GF Seat cover options



Velour black

Alcantara® black
Leather red

Alcantara® red
Leather black

Accessories



ABE sidemount

FIA sidemount

Universal sidemount



Pad Kit M/L
Velour black

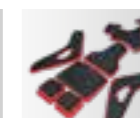

Pad Kit M/L
Alcantara® black
Leather red



Pad Kit M/L
Alcantara® red
Leather black

¹ Temporary removal of pad and pad pins recommended.

² One of the lightest seats in its class: category retrofit seats with road approval and FIA approval.

³ No FIA approval if used with a side airbag.





LIGHTEST SEAT IN THE WORLD¹

FROM SUMMER 2023, ALSO AVAILABLE WITH SIDE AIRBAG



RECARO Podium CF (Carbon fiber reinforced plastic CFRP)

Standard features

- + Carbon fiber reinforced plastic (CFRP) seat shell
- + RECARO Podium CF **M**: with pads for medium build drivers
- + RECARO Podium **L**: with pads for larger build drivers
- + ABE and FIA homologation^{*/**}
- + Suitable for track and road
- + Sporty seat performance
- + Sleek racing seat look
- + Special lateral support
- + Specially formed shoulder support
- + Integrated headrest
- + Visible seat structures
- + Road use: with 3- or 4-point belt
- + FIA: with 4-, 5- or 6-point belt
- + Developed for the use of HANS systems²

+ Lightest seat in the world¹:

- RECARO Podium CF L: approx. 7.3 kg
- RECARO Podium CF M: approx. 7.4 kg (incl. pads in velour black)
- + Net seat weight: only approx. 4.9 kg

Options (at additional cost)

- + Seat cover options with Alcantara®/leather
- + Side airbag³ (available from summer 2023)

Accessories (at additional cost)

- + ABE sidemount
- + FIA sidemount
- + Universal sidemount
- + Pad Kit M and L in the three cover options

*** Seat with ABE (German general type approval)/component certification with 3-point belt available for many vehicles.** For further information on specific vehicles, please contact an authorized RECARO partner (ABE/component certification only in conjunction with RECARO baseframe and sidemount).

**** FIA homologation 8855-1999** only in conjunction with the specified sidemount.



ALCANTARA

RECARO Podium CF Seat cover options

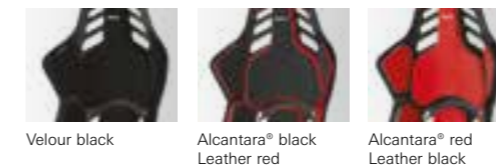

Velour black Alcantara® black Leather red Alcantara® red Leather black

Accessories

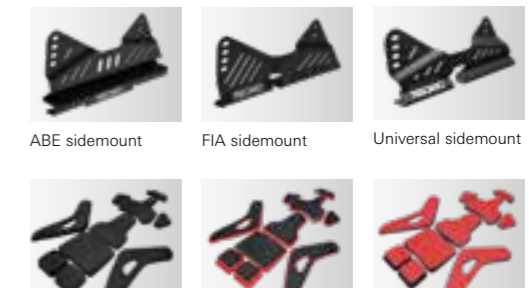

ABE sidemount FIA sidemount Universal sidemount
Pad Kit M/L Velour black Pad Kit M/L Alcantara® black Leather red Pad Kit M/L Alcantara® red Leather black

¹ One of the lightest seats in its class: category retrofit seats with road approval and FIA approval.

² Temporary removal of pad and pad pins recommended.

³ No FIA approval if used with a side airbag.



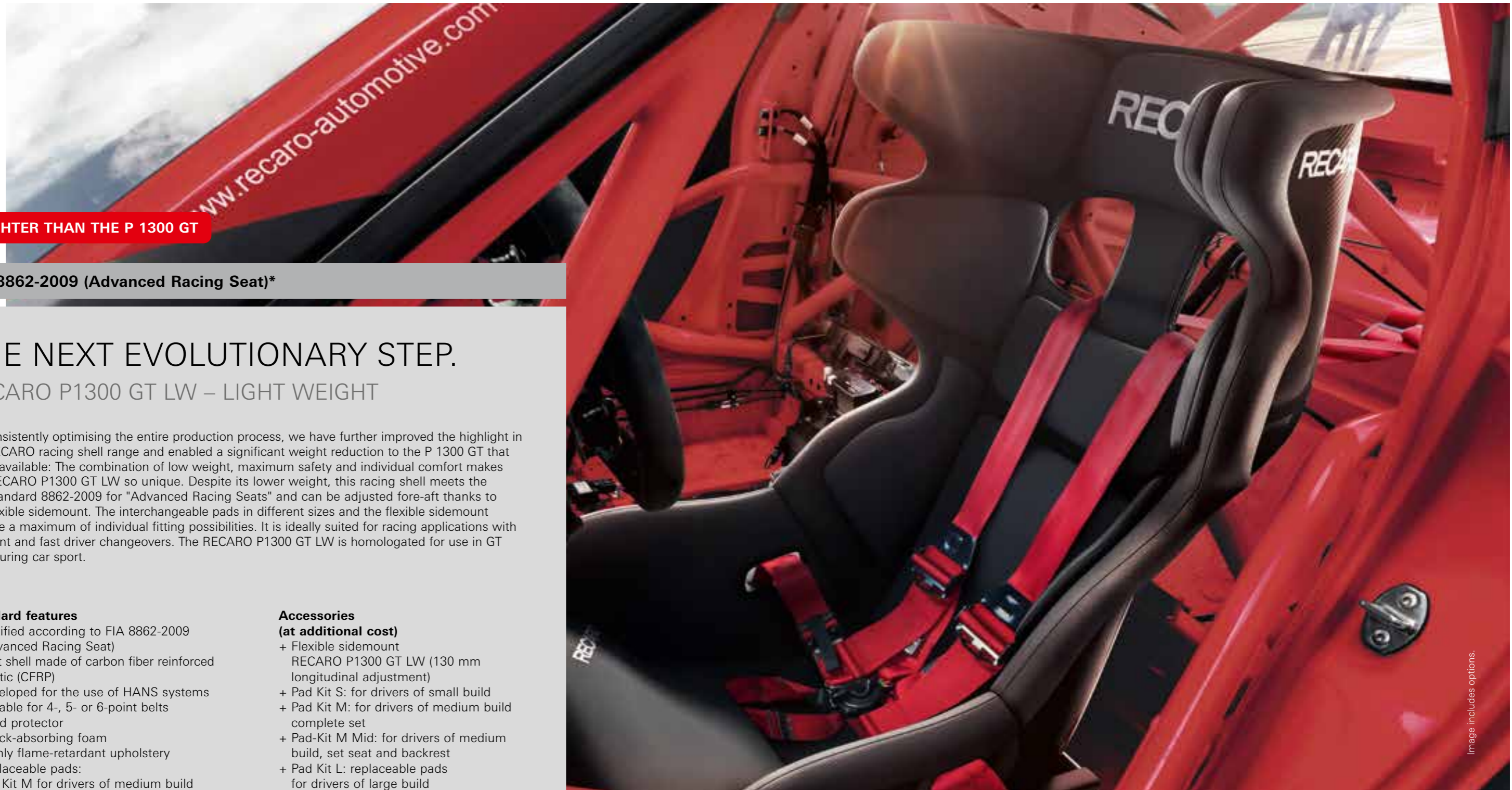

11% LIGHTER THAN THE P 1300 GT

FIA 8862-2009 (Advanced Racing Seat)*

THE NEXT EVOLUTIONARY STEP. RECARO P1300 GT LW – LIGHT WEIGHT

By consistently optimising the entire production process, we have further improved the highlight in the RECARO racing shell range and enabled a significant weight reduction to the P 1300 GT that is still available: The combination of low weight, maximum safety and individual comfort makes our RECARO P1300 GT LW so unique. Despite its lower weight, this racing shell meets the FIA standard 8862-2009 for "Advanced Racing Seats" and can be adjusted fore-aft thanks to the flexible sidemount. The interchangeable pads in different sizes and the flexible sidemount provide a maximum of individual fitting possibilities. It is ideally suited for racing applications with frequent and fast driver changeovers. The RECARO P1300 GT LW is homologated for use in GT and touring car sport.

Standard features

- + Certified according to FIA 8862-2009 (Advanced Racing Seat)
- + Seat shell made of carbon fiber reinforced plastic (CFRP)
- + Developed for the use of HANS systems
- + Suitable for 4-, 5- or 6-point belts
- + Head protector
- + Shock-absorbing foam
- + Highly flame-retardant upholstery
- + Replaceable pads:
Pad Kit M for drivers of medium build (standard feature)
- + FIA approval for 10 years

Accessories

(at additional cost)

- + Flexible sidemount
RECARO P1300 GT LW (130 mm longitudinal adjustment)
- + Pad Kit S: for drivers of small build
- + Pad Kit M: for drivers of medium build complete set
- + Pad-Kit M Mid: for drivers of medium build, set seat and backrest
- + Pad Kit L: replaceable pads for drivers of large build
- + Lumbar pad
- + Side support pad
- + Pad Kit helmet support

RECARO P1300 GT LW is designed for vehicles with a slope angle of 8.5°. This is the only way to enable the tilt setting of 3° during installation.
* FIA approval 8862-2009 (Advanced Racing Seat) only in conjunction with specified sidemounts.



Image includes options.

Upholstery variant



Velour black

Accessories

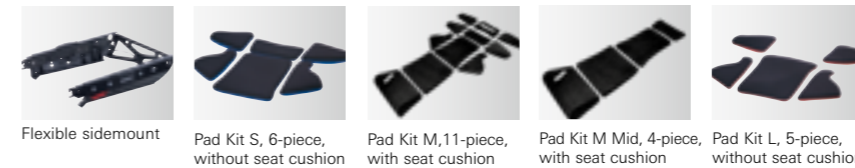

Weight
Approx. 11.0 kg (without pads/upholstery)
Approx. 14.0 kg (with pads/upholstery)

Pad Kit S, M, M Mid, L



FIA 8862-2009 (Advanced Racing Seat)*

THE SEATS FOR WINNERS.

RECARO P 1300 GT

The highlight of the RECARO racing range. The blend of maximum safety and custom comfort is what makes the P 1300 GT so unique. This seat meets FIA Standard 8862-2009 for Advanced Racing Seats. Its interchangeable pads – available in different sizes – give you a wide range of options to tailor the seat to your specific needs. It's ideally suited for racing use with frequent, fast driver changeovers. The P 1300 GT is homologated exclusively for use in GT and touring car sport.

Standard features

- + Certified according to FIA 8862-2009 (Advanced Racing Seat)
- + Seat shell made of carbon fiber reinforced plastic (CFRP)
- + Developed for the use of HANS systems
- + Suitable for 4-, 5- or 6-point belts
- + Head protector
- + Shock-absorbing foam
- + Highly flame-retardant upholstery
- + Replaceable pads:
 - Pad Kit M for drivers of medium build (standard feature)
- + FIA approval for 10 years

Accessories

(at additional cost)

- + Fixed sidemount RECARO P 1300 GT
- + Pad Kit S: for drivers of small build
- + Pad Kit M: for drivers of medium build complete set
- + Pad-Kit M Mid: for drivers of medium build, set seat and backrest
- + Pad Kit L: replaceable pads for drivers of large build
- + Lumbar pad
- + Side support pad
- + Pad Kit helmet support



RECARO P 1300 GT LW is designed for vehicles with a slope angle of 8.5°. This is the only way to enable the tilt setting of 3° during installation.
 * FIA approval 8862-2009 (Advanced Racing Seat) only in conjunction with specified sidemounts.



GT SPORT	TOURING SPORT			CFRP
RACE 4-5-6-POINT BELT	HANS	ANTI SHOCK	ADVANCED SEAT 10 YEARS	

Upholstery variant



Velour black

Weight
 Approx. 12.3 kg (without pads/upholstery)
 Approx. 15.3 kg (with pads/upholstery)

Accessories

Fixed sidemount	Pad Kit S, 6-piece, without seat cushion	Pad Kit M, 11-piece, with seat cushion	Pad Kit M Mid, 4-piece, with seat cushion	Pad Kit L, 5-piece, without seat cushion
Lumbar pad	Side support pad	Pad Kit helmet support		

Pad Kit S, M, M Mid, L

Photo shows options.



Image includes options

FIA 8855-1999 (Competition Seat)*

FOR PROS WITH A CLAIM TO WINNING.

RECARO Pro Racer SPA & SPG

The RECARO Pro Racer – our premium product for GT and touring cars built to the FIA 8855-1999 standard – was developed for HANS driver safety systems and comes in four versions. The seat is available in carbon-aramid composite (CFRP/AFRP) or glass fiber reinforced plastic (GFRP), and in various sizes, including an XL option for drivers of larger build. The Pro Racer fits like a glove. And the FIA-homologated flexible sidemount accommodates any driver's physique with ease.

Standard features

- + Developed for the use of HANS systems
- + Suitable for 4-, 5- or 6-point belts
- + Head protector
- + Shock-absorbing foam
- + Flame-retardant upholstery
- + Friction grip surface around the shoulders

RECARO Pro Racer SPA & XL

- + Seat shell made of carbon and aramid composite (CFRP/AFRP)
- + **XL:** seat shell 35 mm wider

RECARO Pro Racer SPG & XL

- + Seat shell made of glass fiber reinforced plastic (GFRP)
- + **XL:** seat shell 35 mm wider

Accessories (at additional cost)

- + Steel sidemount
- + Aluminum sidemount
- + Flexible sidemount ideal for races with change of driver
- + Seat cushion



* FIA approval 8855-1999 only valid in conjunction with the specified RECARO sidemount.

Weight

- Pro Racer SPA: approx. 7.0 kg
- Pro Racer SPA XL: approx. 7.5 kg
- Pro Racer SPG: approx. 9.0 kg
- Pro Racer SPG XL: approx. 10.0 kg

Upholstery variant



Velour black

Accessories



Flexible sidemount Pro Racer SPG/SPA



Flexible sidemount Pro Racer SPG/SPA XL



Pro Racer SPG & SPA: Steel sidemount



Pro Racer SPG XL: Steel sidemount



Pro Racer SPA XL: Aluminum sidemount

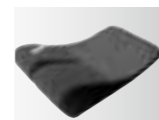

Pro Racer SPG & SPA: High seat cushion

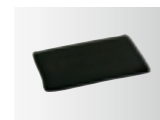

Lumbar pad



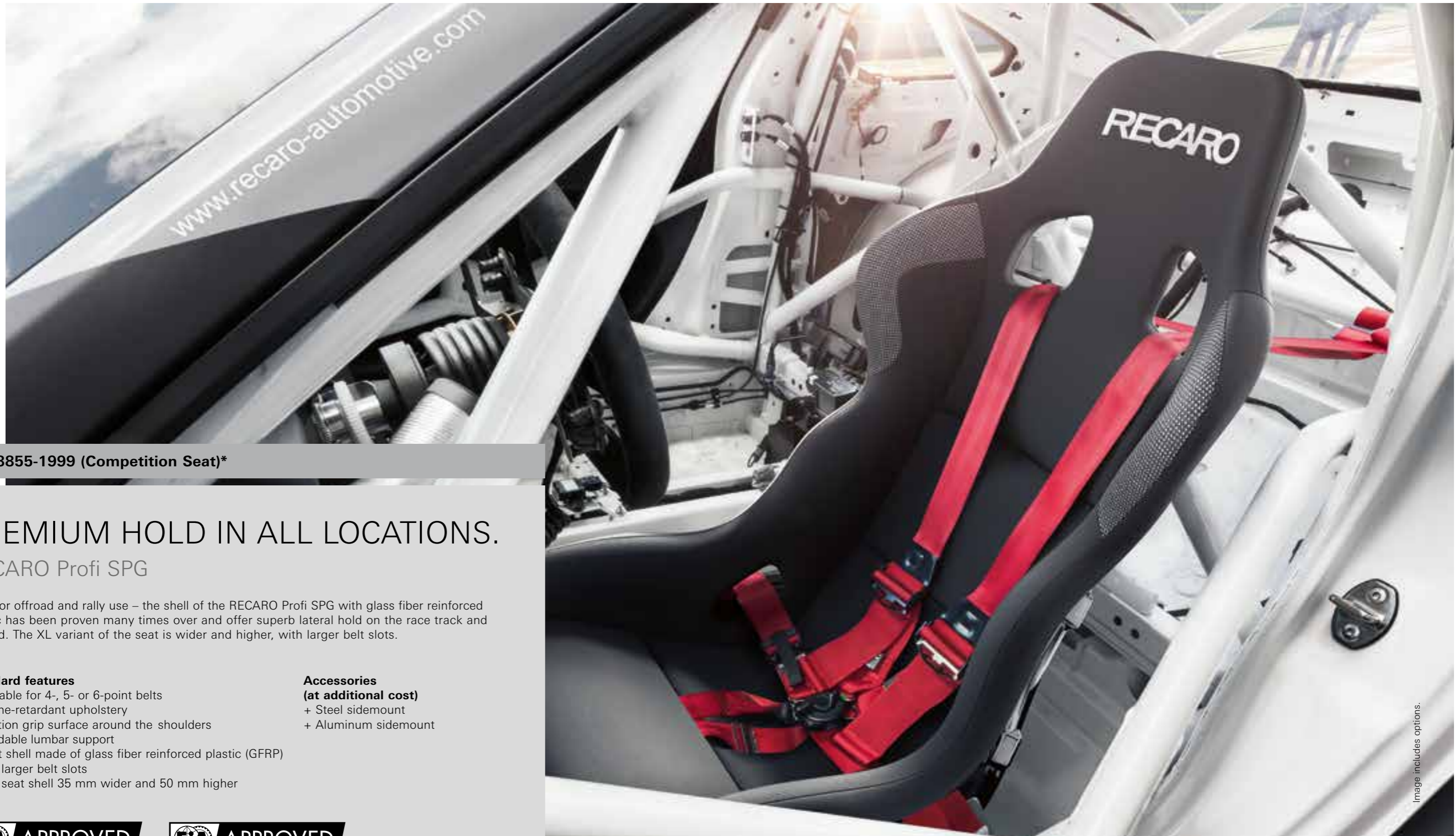

FIA 8855-1999 (Competition Seat)*

PREMIUM HOLD IN ALL LOCATIONS.

RECARO Profi SPG

Ideal for offroad and rally use – the shell of the RECARO Profi SPG with glass fiber reinforced plastic has been proven many times over and offer superb lateral hold on the race track and offroad. The XL variant of the seat is wider and higher, with larger belt slots.

Standard features

- + Suitable for 4-, 5- or 6-point belts
- + Flame-retardant upholstery
- + Friction grip surface around the shoulders
- + Paddable lumbar support
- + Seat shell made of glass fiber reinforced plastic (GFRP)
- + **XL**: larger belt slots
- + **XL**: seat shell 35 mm wider and 50 mm higher

Accessories

- (at additional cost)
- + Steel sidemount
 - + Aluminum sidemount



* FIA approval 8855-1999 only valid in conjunction with the specified RECARO sidemount.

Image includes options.

Upholstery variants RECARO Profi SPG & XL



Velour black

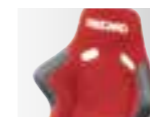

Velour red

Accessories



Profi SPG:
Steel sidemount



Profi SPG XL:
Aluminum sidemount

Weight

Profi SPG: approx. 7.0 kg
Profi SPG XL: approx. 10.0 kg





FIA 8855-1999 (Competition Seat)*

FOR START TO FINISH VICTORIES.

RECARO Pole Position N.G. (FIA)

The RECARO Pole Position N.G. (FIA) racing seat provides the best starting position for all beginners and professionals seeking to compete for podium places from the front row. Its generous array of features and numerous options for personalizing the cushions and seat covers make it the popular favorite in GT, touring cars and club motorsport.

Standard features

- + Seat shell made of glass fiber reinforced plastic (GFRP)
- + Suitable for 4-, 5- or 6-point belts
- + Flame-retardant upholstery
- + Seat and backrest cushions replaceable
- + Paddable lumbar support

Accessories

- (at additional cost)**
- + Steel sidemount
 - + Aluminium sidemount



* FIA approval 8855-1999 only valid in conjunction with the specified RECARO sidemount.

Image includes options.

Upholstery variants



Velour black

Velour red

Accessories



Steel sidemount

Steel sidemount

Aluminium sidemount

Weight
Approx. 7.7 kg





FIA 8855-1999 (Competition Seat)**

FOR TRACK AND ROAD.

RECARO Podium CF (Carbon fiber) and GF (Glass fiber)

The new RECARO Podium is much more than a thoroughbred GFRP or CFRP shell seat. It's a pioneering seat design for the contrasting demands of road and track. It's not just its sleek outline, visible structures or motorsport-inspired pads in varying thicknesses that make heads turn. The Podium stands out because of its superior quality and exceptional performance on all road types – for driving day-to-day and at the limit. The RECARO Podium is the only retrofit shell seat on the market that is approved for use on public roads and has FIA homologation. Racing technology doesn't get better than this!

To meet our consistently high standards of innovation, quality, comfort and, most importantly, safety, the RECARO Podium went through intensive testing on the toughest racetracks in the world during development.

The suave combination of original Alcantara® fabrics and exclusive leather together with the passive ventilation of the open back shell and airy pad contours make even the longest of routes the most perfect of pleasures. In addition, the RECARO Podium is the first racing shell ever to be awarded the coveted seal of quality from AGR e.V., the German Campaign for Healthier Backs – a reliable decision-making aid when buying back-friendly products. The shell is also super light – but, of course, that goes without saying.

RECARO Podium GF/CF M for medium build drivers

The RECARO Podium M is suitable for medium build drivers. The approx. **20 mm** thick pads are available in all of the listed cover options.

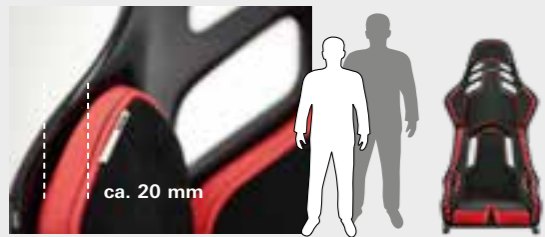

RECARO Podium GF/CF L for larger build drivers

The RECARO Podium L is suitable for larger build drivers. The approx. **10 mm** thick pads are available in all of the listed cover options.

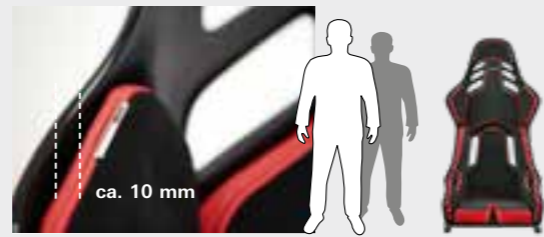

AGR: Approved and recommended by Healthier Backs Association (Aktion Gesunder Rücken e.V.) and the Federal Association of German Back Schools (BdR) e. V. For more information, contact: AGR e. V., Stader Str. 6, 27432 Bremervörde, Germany, Phone +49 4761 926 358 0, www.agr-ev.de/en/back-friendly-products/back-friendly-products/4853-car-racing-shells

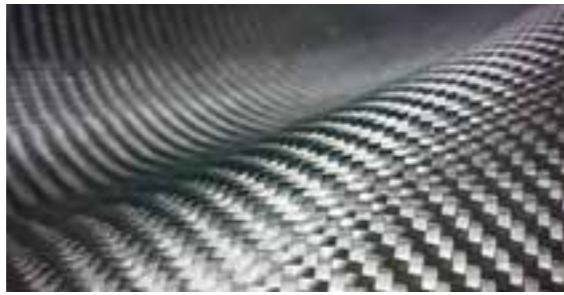

**LIGHTEST SEAT
IN THE WORLD¹**



RECARO Podium CF (Carbon fiber reinforced plastic CFRP)

Standard features

- + Carbon fiber reinforced plastic (CFRP) seat shell
- + RECARO Podium CF **M**: with pads for medium build drivers
- + RECARO Podium **L**: with pads for larger build drivers
- + ABE and FIA homologation^{*/**}
- + Suitable for track and road
- + Sporty seat performance
- + Sleek racing seat look
- + Special lateral support
- + Specially formed shoulder support
- + Integrated headrest
- + Visible seat structures
- + Road use: with 3- or 4-point belt
- + FIA: with 4-, 5- or 6-point belt
- + Developed for the use of HANS systems²

+ Lightest seat in the world¹:

- RECARO Podium CF L: approx. 7.3 kg
- RECARO Podium CF M: approx. 7.4 kg (incl. pads in velour black)
- + Net seat weight: only approx. 4.9 kg

Options (at additional cost)

- + Seat cover options with Alcantara®/leather

Accessories (at additional cost)

- + FIA sidemount
- + Universal sidemount
- + Pad Kit M and L in the three cover options



*** Seat with ABE (German general type approval)/component certification with 3-point belt available for many vehicles.**
For further information on specific vehicles, please contact an authorized RECARO partner (ABE/component certification only in conjunction with RECARO baseframe and sidemount).
**** FIA homologation 8855-1999** only in conjunction with the specified sidemount.

ALCANTARA

RECARO Podium CF Seat cover options

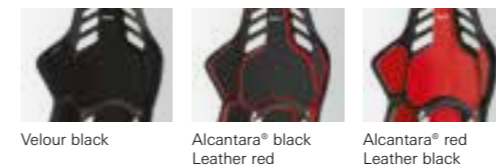

Accessories

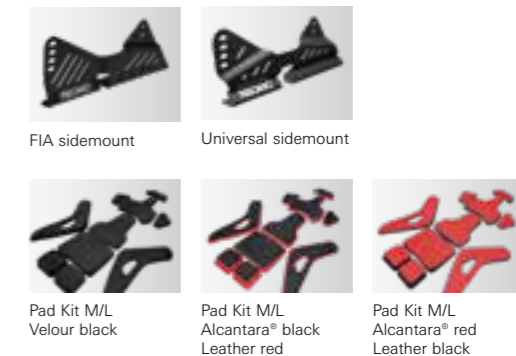

¹ One of the lightest seats in its class: category retrofit seats with road approval and FIA approval.

² Temporary removal of pad and pad pins recommended.





NEW



RECARO Podium GF (Glass fiber reinforced plastic GFRP)

Standard features

- + Glass fiber reinforced plastic (GFRP) seat shell
- + RECARO Podium GF **M**: with pads for medium build drivers
- + RECARO Podium GF **L**: with pads for larger build drivers
- + ABE and FIA homologation
- + Suitable for track and road
- + Sporty seat performance
- + Sleek racing seat look
- + Special lateral support
- + Specially formed shoulder support
- + Integrated headrest
- + High-grade surface in mirror-finish black gelcoat
- + Road use: with 3- or 4-point belt
- + FIA: with 4-, 5- or 6-point belt

- + Developed for the use of HANS systems¹
- + **One of the lightest seats in the world²:**
 RECARO Podium GF L: approx. 10.9 kg
 RECARO Podium GF M: approx. 11.0 kg (including pads in black velour)
- + Net seat weight: only approx. 8.5 kg

Options (at additional cost)

- + Seat cover options with Alcantara®/leather

Accessories (at additional cost)

- + FIA sidemount
- + Universal sidemount
- + Pad Kit M and L in the three cover options

*** Seat with ABE (German general type approval)/component certification with 3-point belt available for many vehicles.**
 For further information on specific vehicles, please contact an authorized RECARO partner (ABE/component certification only in conjunction with RECARO baseframe and sidemount).
**** FIA homologation 8855-1999 only in conjunction with the specified sidemount.**



ALCANTARA

RECARO Podium GF Seat cover options

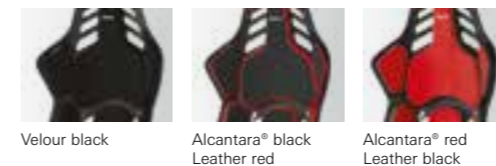

Velour black Alcantara® black Leather red Alcantara® red Leather black

Accessories

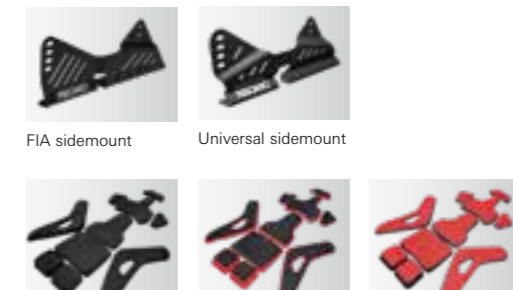

FIA sidemount Universal sidemount
 Pad Kit M/L Velour black Pad Kit M/L Alcantara® black Leather red Pad Kit M/L Alcantara® red Leather black

¹ Temporary removal of pad and pad pins recommended.

² One of the lightest seats in its class: category retrofit seats with road approval and FIA approval.



RECARO UPHOLSTERY MATERIALS

Nardo:
In combination with the Artista upholstery, this ultra-durable material keeps your side bolsters in perfect shape for a very long time.

Nardo gray
Nardo black

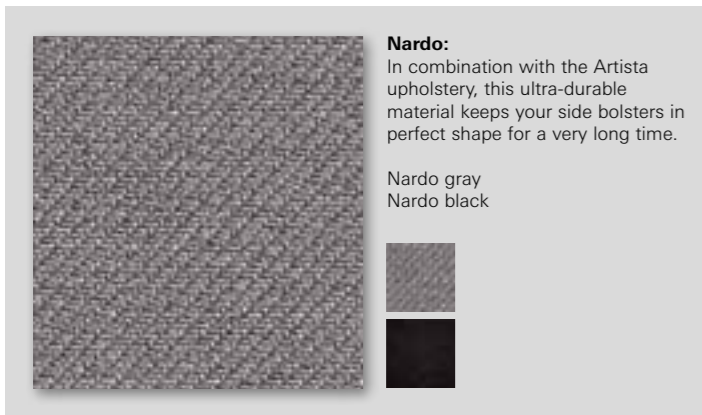

Artista:
A timelessly elegant fabric for a refined interior. Guarantees longevity and durability.

Artista gray
Artista black



Velour:
A robust, easy-care fabric which is also used to upholster RECARO motorsport racing shells.

Velour black

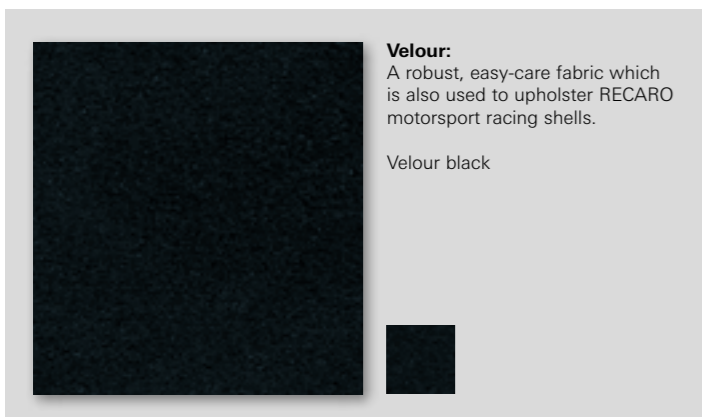

Dinamica suede:
This exclusive upholstery is highly durable and easy-care with a premium feel. The material is also breathable, vegan, light, and even hypoallergenic.

Dinamica suede red
Dinamica suede silver
Dinamica suede black
Dinamica suede grey

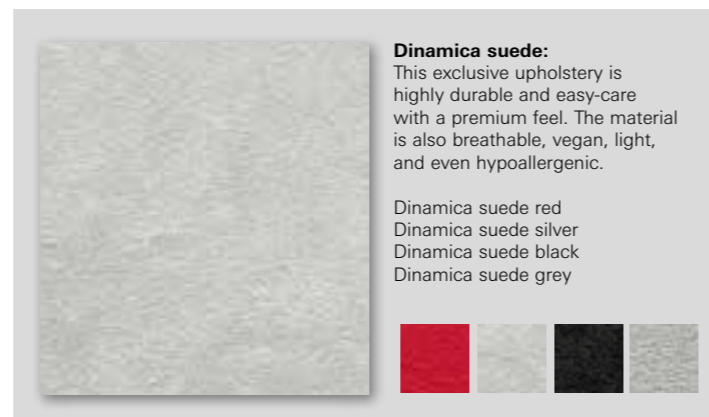

Ambla leather:
RECARO Ambla leather is a high-quality, highly durable easy-care alternative to leather.

Ambla leather black



Alcantara®:
Alcantara is a Carbon Neutral material made in Italy which offers an unparalleled combination of aesthetic, technical and sensory qualities. It is elegant, soft but also breathable, light and wear resistant, able to turn car interiors into exclusive and special environments.

Alcantara black
Alcantara red

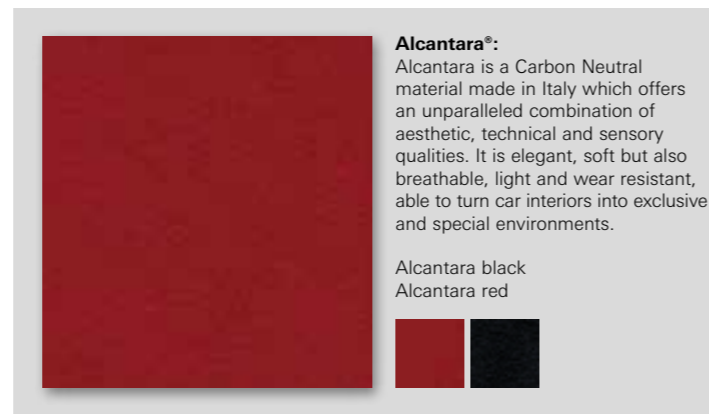

Leather:
RECARO leather is a high-quality natural product designed for exacting requirements.

Leather black
Leather red
Leather white

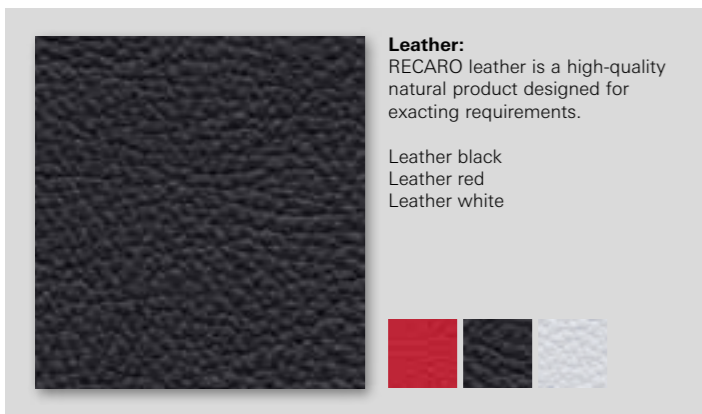

Notes: Customers may provide their own bespoke upholstery materials. These must be suitable and approved for use in the automotive sector. The seat air conditioning and heating functions may be restricted as a result. For seats with a side airbag we recommend that you contact an approved consultant in advance. Current seat upholstery from selected automotive manufacturers is available on request (restrictions apply).

RECARO SEATING TRAINING

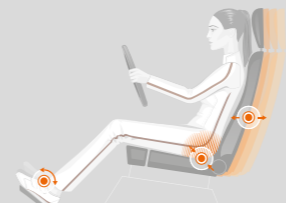
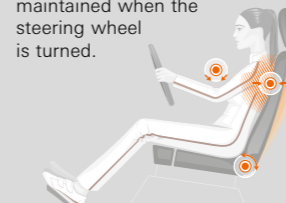
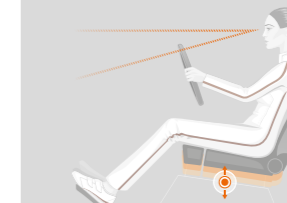
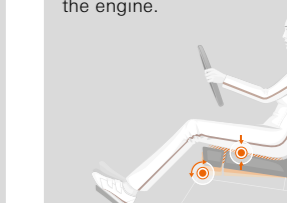
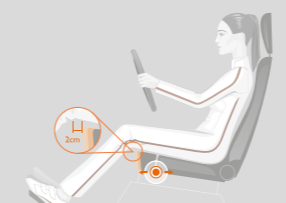
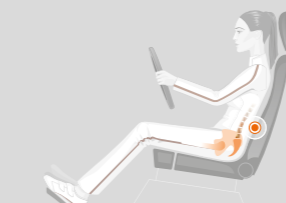
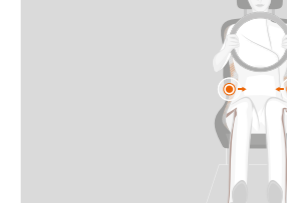
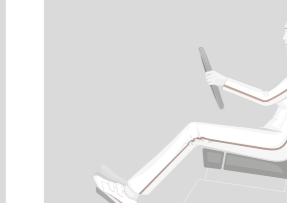
1. Push your bottom as near as possible to the backrest. The distance from the seat to the pedals is adjusted so that your knee is slightly bent when the pedals are fully depressed.
 
2. Rest your shoulders as closely as possible on the backrest. Set the backrest tilt so that the steering wheel is easy to reach with slightly bent elbows. Shoulder contact must be maintained when the steering wheel is turned.
 
3. Set the seat height as high as possible. This ensures an unobstructed view to all sides and all displays on the instrument panel.
 
4. Set the seat cushion tilt so that it is easy to depress the pedals fully. The thighs should rest gently on the seat cushion without exerting pressure on it. Check the backrest tilt before starting the engine.
 
5. Adjust the extendable seat cushion so that the thighs rest on it to just above the knee. Rule of thumb: two to three fingers Space between the edge of the seat and the hollow of the knee.
 
6. The lumbar support has been adjusted correctly when the lumbar part of the back is supported in its natural shape.
 
7. The seat's side bolsters should fit so snugly to the body that the upper body is supported comfortably at the sides without being restricted.
 
8. If possible, adjust the upper edge of the headrest to the same height as the top of the head. Tilt: The distance to the head should be approx. 2 cm.
 

EXPERIENCE RECARO DIFFERENTLY: RECARO AUTOMOTIVE LIFESTYLE.

You can also experience RECARO seats outside the car: With our RECARO Star swivel chairs and the 24/7 chairs, we bring the dynamics and sporty design from the road directly to the workplace; with RECARO Maritime seats for boats and yachts, skippers enjoy comfort and ergonomic support on the high seas, and football stars not only like to sit in RECARO seats in their vehicles – players, coaches and physiotherapists all count on RECARO as an expert for ergonomic sitting in the stadium.





BUY DIRECTLY ONLINE

shop.recaro-automotive.com

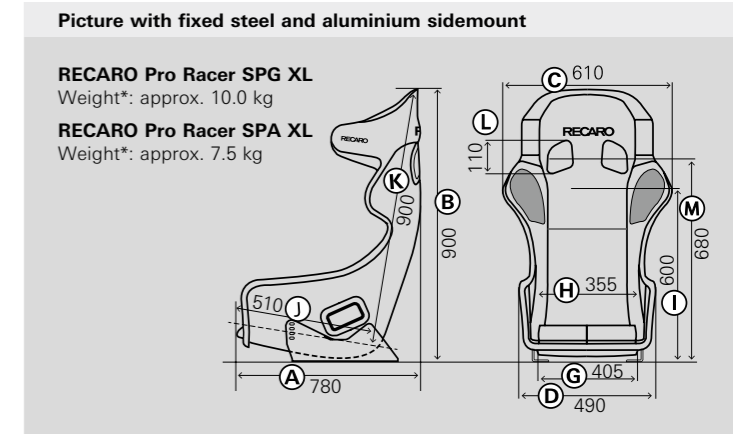
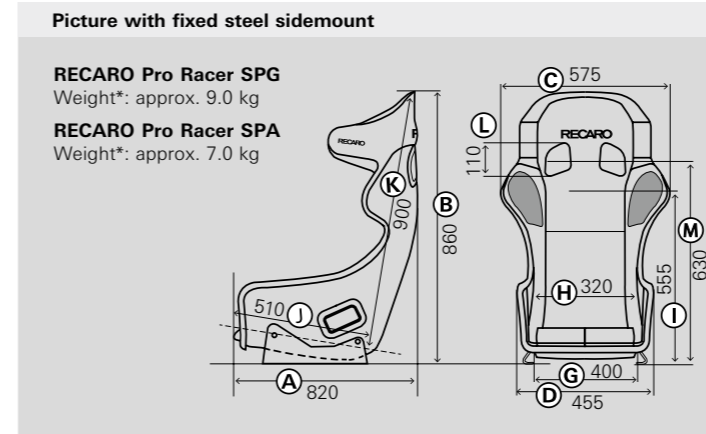
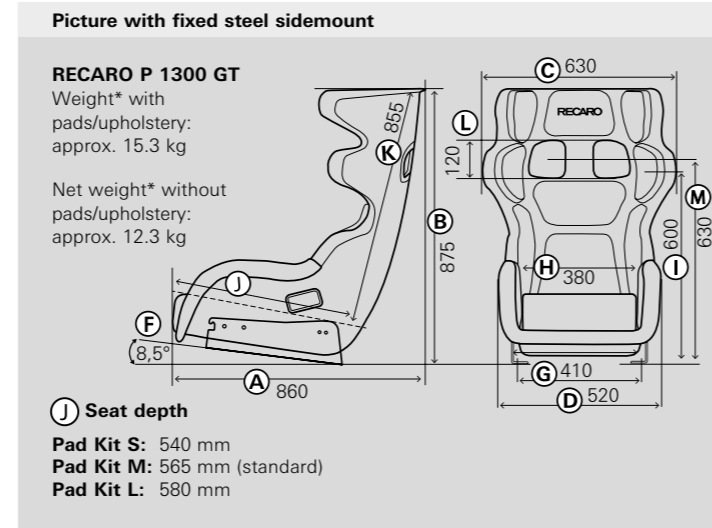
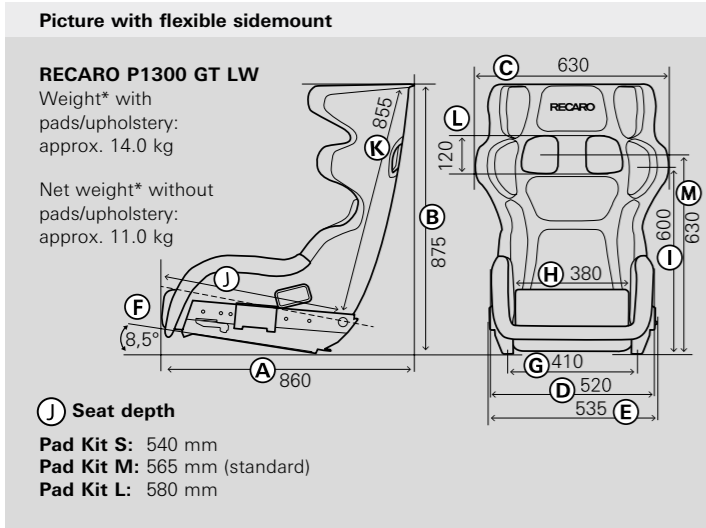

FIA-HOMOLOGATION 8862-2009 (Advanced Racing Seat)

FIA HOMOLOGATION 8855-1999 (Competition Seat)



NOTES: FIA-Homologation 8862-2009 (Advanced Racing Seat) and FIA-Homologation 8855-1999

KEY:

- Overall dimensions:**
A: Seat depth
B: Seat height
C: Shell outer measurement at shoulder
D: Shell outer measurement at seat bottom
E: Subframe width
F: Tilt at mounting level
G: Width between mounting bolts
- Comfort dimensions:**
H: Seat width at bottom
I: Height of shoulder support
J: Seat depth
K: Seat height
- Belt slot:**
L: Height of belt slot
M: Center belt slot

NOTES ON COMFORT DIMENSIONS:

- Dimensions in mm. All dimensions may vary by ±10 mm.
- They do not take account of upholstery movement when the driver is seated, since this can vary a great deal. The comfort dimensions are measured on the upholstery and seams. Small deviations cannot be excluded.
- The **seat height** indicates the vertical height of the backrest from the top of the headrest to the top of the seat cushion.
- The **seat width** indicates the width of the seat cushion. This dimension is measured at the highest, forwardmost edge of the lateral center belt slot and can be up to 40 mm wider depending on how the seat cushions respond to the driver when seated.
- The **seat depth** indicates the total horizontal length of the seat cushion (from the front of the cushion to the bottom of the backrest).

NOTE:

- * Weight: total shell weight (without mounted parts).
- Dimensions in mm.
- The dimensions of the racing seats RECARO Pole Position N.G. (FIA), Profi SPG, Profi SPG XL, Pro Racer SPG/SPA, Pro Racer SPG/SPA XL and P 1300 GT were determined in standard position (upper mounting point at front and lower mounting point at rear).
- The dimensions of the RECARO P1300 GT LW were determined in the rearmost position.
- RECARO racing shells can be individually fitted into nearly all racing cars. Not permitted in the area of the StVO – excluding FIA/ASN licensed events.
- The RECARO Podium racing shell can be installed individually in all racing cars. It is also approved in the StVO (ABE) area.
- FIA approval 8855-1999 and 8862-2009 (Advanced Racing Seat) apply only in conjunction with specified sidemount.
- FIA homologation 8855-1999 only in combination with the associated sidemount for the following RECARO racing seats: RECARO Pole Position N.G. (FIA), Profi SPG, Profi SPG XL, Pro Racer SPG, Pro Racer SPG XL, Pro Racer SPA, Pro Racer SPA XL.
- FIA homologation 8862-2009 (advanced racing seat) only in combination with the associated sidemount for the following RECARO racing seats: RECARO P1300 GT LW, P 1300 GT.
- The RECARO motorsport seats are made by hand to our highest quality standards. Due to this special manufacturing process, the lamination may in exceptional instances result in slight tolerances to the specified dimensions and weights.
- RECARO P1300 GT LW and RECARO P 1300 GT: the sidemounts are geared in their design to a floor pan tilt of 8.5°. Depending on manufacturer and floor pan group, adaptations may be necessary when fitting. RECARO P1300 GT LW: 130 mm lengthways adjustment; angle of tilt variable by max. 3° during fitting.

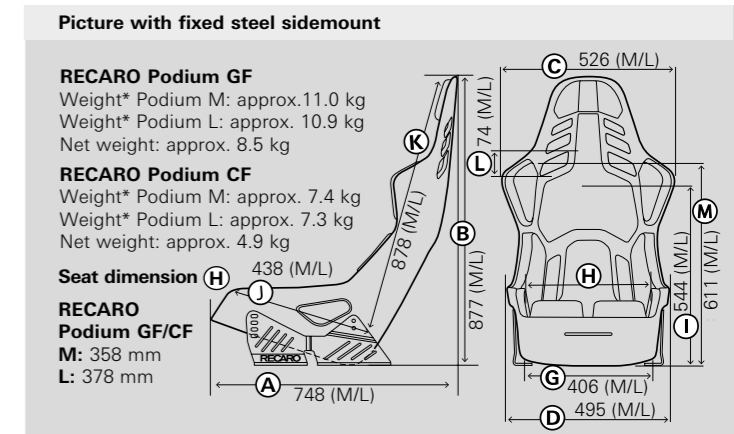
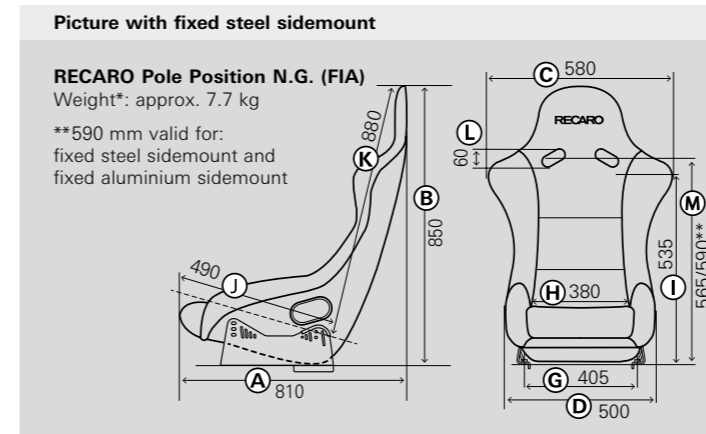
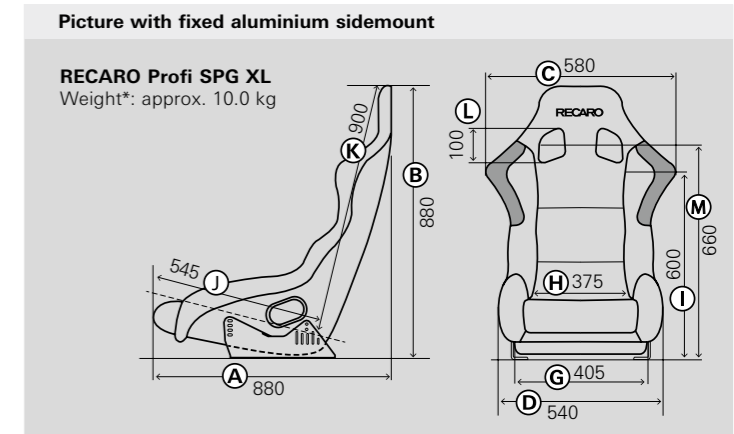
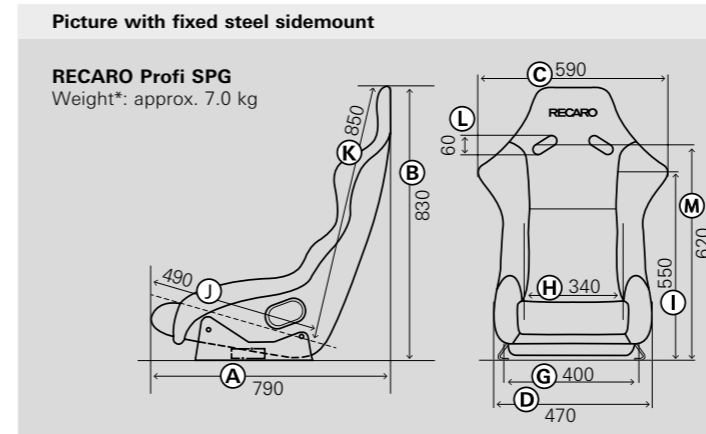
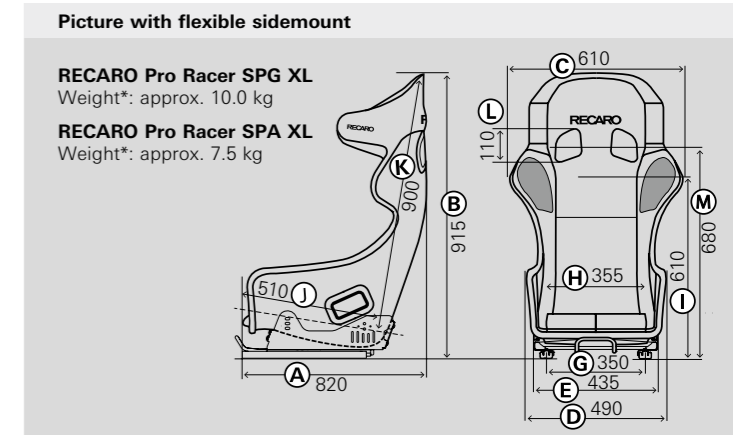
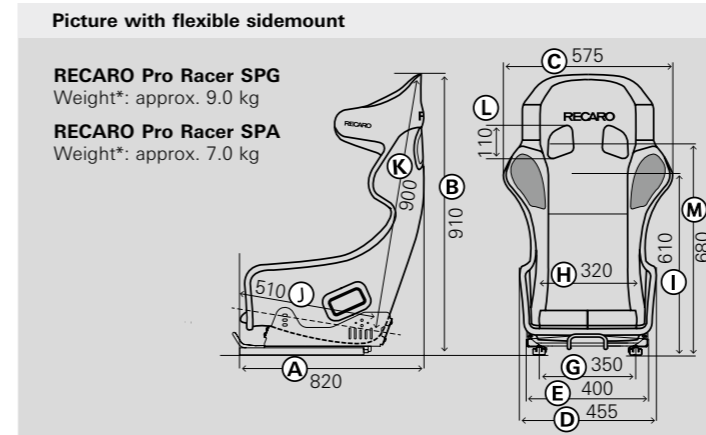

RECARO upholstery materials

Perlon Velour black and red:
Rugged, easy-care fabric that meets top safety standards. All upholstery materials used in RECARO racing shells meet FIA 8862-2009 homologation standards and are tested to ISO 3795. RECARO products designed to FIA Standard 8855-1999 are tested to fabric flammability standard FMVSS 302 and exceed the flame retardancy requirements by a significant margin.

Alcantara® black and red:
Alcantara is a Carbon Neutral material made in Italy which offers an unparalleled combination of aesthetic, technical and sensory qualities. It is elegant, soft but also breathable, light and wear resistant, able to turn car interiors into exclusive and special environments.





Leather:
RECARO leather is a high-quality natural product for exacting requirements for the vehicle interior.

FIA HOMOLOGATION 8862-2009 (Advanced Racing Seat)

FIA HOMOLOGATION 8855-1999 (Competition Seat)

<p>Flexible sidemount*</p> <p>For RECARO racing seat: RECARO P1300 GT LW</p> 		<p>Weight: 10.7 kg</p> 	 <p>MANUFACTURER: RECARO MODEL: P1300 GT LW HOM. NO.: AS.082.13 FIA STANDARD: 8862-2009</p>
<p>Steel sidemount**</p> <p>For RECARO racing seat: RECARO P 1300 GT</p>		<p>Weight: 4.1 kg</p> 	 <p>MANUFACTURER: RECARO MODEL: P 1300 GT HOM. NO.: AS.027.12 FIA STANDARD: 8862-2009</p>
<p>Pad Kit S</p> <p>For RECARO racing seats: RECARO P1300 GT LW RECARO P 1300 GT</p> <p>Pads for drivers of smaller build, 6-piece, without seat cushion</p> 		<p>Lumbar pad</p> <p>For RECARO racing seats: RECARO P1300 GT LW RECARO P 1300 GT RECARO Pro Racer SPA & SPG</p> <p>Upholstery: Velour black</p> 	
<p>Pad Kit M</p> <p>For RECARO racing seats: RECARO P1300 GT LW RECARO P 1300 GT</p> <p>Pads for drivers of medium build, 11-piece, with seat cushion</p> 		<p>Pad Kit helmet support</p> <p>For RECARO racing seats: RECARO P1300 GT LW RECARO P 1300 GT</p> <p>Upholstery: Velour black</p> 	
<p>Pad Kit M Mid</p> <p>For RECARO racing seats: RECARO P1300 GT LW RECARO P 1300 GT</p> <p>Pads for drivers of medium build, 4-piece, with seat cushion</p> 		<p>Side support pad</p> <p>For RECARO racing seats: RECARO P1300 GT LW RECARO P 1300 GT</p> <p>Upholstery: Velour black</p> 	
<p>Pad Kit L</p> <p>For RECARO racing seats: RECARO P1300 GT LW RECARO P 1300 GT</p> <p>Pads for drivers of larger build, 5-piece, with seat cushion</p> 			

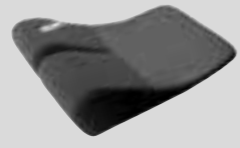
FIA-HOMOLOGATION 8855-1999 (Competition Seat)

<p>Pad Kit M</p> <p>For RECARO racing seat: RECARO Podium</p> <p>10-piece Upholstery: Velours black Alcantara® black/Leather red Alcantara® red/Leather black</p> 		<p>Pad Kit L</p> <p>For RECARO racing seat: RECARO Podium</p> <p>10-piece Upholstery: Velours black Alcantara® black/Leather red Alcantara® red/Leather black</p> 	
<p>High seat cushion</p> <p>For RECARO racing seat: RECARO Pro Racer SPG/SPA</p> <p>Height: approx. 55 mm Upholstery: Velour black</p> 		<p>Lumbar pad</p> <p>For RECARO racing seats: RECARO Pro Racer SPG/SPA, SPG/SPA XL</p> <p>Upholstery: Velour black</p> 	

<p>FIA sidemount</p> <p>For RECARO racing seats: RECARO Podium GF RECARO Podium CF</p>		<p>Weight: 2.6 kg</p> 	 <p>MANUFACTURER: RECARO MODEL: Podium HOM. NO.: CS.456.20 FIA STANDARD: 8855-1999</p>
<p>Universa sidemount***</p> <p>For RECARO racing seats: RECARO Podium GF RECARO Podium CF</p>		<p>Weight: 2,9 kg</p> 	 <p>MANUFACTURER: RECARO MODEL: PODIUM CF HOM. NO.: CS.456.20 FIA STANDARD: 8855-1999</p>
<p>Aluminum sidemount</p> <p>For RECARO racing seats: RECARO Pole Position N.G. (FIA) RECARO Profi SPG XL RECARO Pro Racer SPA XL</p>		<p>Weight: 1.1 kg</p> 	 <p>MANUFACTURER: RECARO MODEL: Pole Position N.G. (FIA) / PROFI SPG XL / PRO RACER SPA XL HOM. NO.: CS.319.14 HOM. NO.: CS.086.04 HOM. NO.: CS.461.20 FIA STANDARD: 8855-1999</p>
<p>Steel sidemount</p> <p>For RECARO racing seats: RECARO Pole Position N.G. (FIA) RECARO Pro Racer SPG XL</p>		<p>Weight: 2.6 kg</p> 	 <p>MANUFACTURER: RECARO MODEL: Pole Position N.G. (FIA) / Pro Racer SPG XL HOM. NO.: CS.319.14 HOM. NO.: CS.135.05 FIA STANDARD: 8855-1999</p>
<p>Steel sidemount</p> <p>For RECARO racing seats: RECARO Profi SPG RECARO Pro Racer SPG/SPA</p>		<p>Weight: 2.0 kg</p> 	 <p>MANUFACTURER: RECARO MODEL: PROFI SPG / PRO RACER SPG / PRO RACER SPA HOM. NO.: CS.011.00 HOM. NO.: CS.305.14 HOM. NO.: CS.460.20 FIA STANDARD: 8855-1999</p>
<p>Steel sidemount</p> <p>For RECARO racing seats: RECARO Pole Position N.G. (FIA)</p>		<p>Weight: 3.3 kg</p> 	 <p>MANUFACTURER: RECARO MODEL: POLE POSITION N.G. (FIA) HOM. NO.: CS.319.14 FIA STANDARD: 8855-1999</p>
<p>Flexible sidemount</p> <p>For RECARO racing seats: RECARO Pro Racer SPG/SPA</p> 		<p>Weight: 6.9 kg</p> 	 <p>MANUFACTURER: RECARO MODEL: PRO RACER SPG / PRO RACER SPA HOM. NO.: CS.305.14 HOM. NO.: CS.460.20 FIA STANDARD: 8855-1999</p>
<p>Flexible sidemount</p> <p>For RECARO racing seats: RECARO Pro Racer SPG/SPA XL</p> 		<p>Weight: 7.7 kg</p> 	 <p>MANUFACTURER: RECARO MODEL: PRO RACER SPG XL / PRO RACER SPA XL HOM. NO.: CS.135.05 HOM. NO.: CS.461.20 FIA STANDARD: 8855-1999</p>

* The sidemounts are designed for a ground angle of 8.5°. Adjustments may be required during installation depending on the manufacturer and ground group. (130 mm longitudinal adjustment, inclination angle variable by max. 3° during mounting)
 ** The sidemounts are designed for a ground angle of 8.5°. Adjustments may be required during installation depending on the manufacturer and ground group.
 *** For use in ABE and FIA application.

RECARO SYMBOLS

USE



Seat for GT vehicles



Seat for touring cars



Seat for rally vehicles

CUSTOM DRIVER COMFORT



Lumbar support



Flexible sidemount (fore-aft adjustment), ideal for racing use with change of driver



Replaceable pads (S/M/L), individually adjustable to the driver's build



Replaceable pads (M/L), individually adjustable to the driver's build



XL seat – ideal for people of large build



Passive seat air conditioning

LIGHTWEIGHT CONSTRUCTION



Seat made of lightweight composites



Seat shell made of carbon fiber reinforced plastic



Seat shell made of carbon and aramid fiber reinforced plastic



Seat shell made of glass fiber reinforced plastic

SAFETY MOTORSPORT



Suitable for 4-, 5- und 6-point belt



Racing seat with shock-absorbing foam



FIA homologation for 5 years



FIA homologation for 10 years



Racing seat optimized for the HANS system

SAFETY ROAD USE



Seat with ABE (German general type approval)/ component certification



Suitable for 3- and 4-point belt



FIA-approved racing seat or sidemount.

The new 'FIA Approved' logo indicates which product from the respective manufacturer is approved under which official homologation number according to the FIA standard.

MANUFACTURER: Information about the manufacturer

MODEL: Product designation

HOM. NO: Number under which the product is homologated

FIA STANDARD: Information about the approved FIA standard

RECARO Automotive
Stuttgarter Strasse 73
73230 Kirchheim/Teck
Germany

Phone: +49 7021 93-5000

E-mail: info@recaro-automotive.com
Internet: www.recaro-automotive.com
shop.recaro-automotive.com

